

Training Systems for Automation Technology

Acquiring Practical Skills and
Project-Oriented Expertise

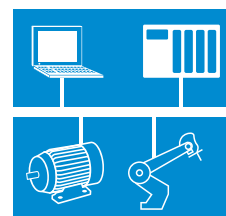

Table fo Contents

Qualifications through Quality	
Training Systems for Automation Technology	4
Different Systems to Fit Differing Needs	
Our Objective Is to Meet Everyone's Standards	6
Presenting Complex Training Content in a Vivid Way	
Project-Oriented Training Media – Adaptable to All Training Systems	10
The Entire System at a Glance	12
More than Just a Training System	
A Total Solution – the Automation Laboratory	14
Instrumentation and Automatic Control Technology	16
Sensor Technology in Automation	18
Measurement of Electrical Variables	19
Measurement of Non-Electrical Variables	20
RLC Measurement	22



Table of Contents

Practical Introduction to Automatic Control Technology	23
Analysis of Control Loops	24
Design and Optimisation of Controllers	25
Applied Automatic Control Technology	26
Automatic Control Technology in Automation Engineering	29
Industrial Installation Technology	30
Manually Operated Switches in a Three-Phase Circuit	32
Contactors Protective Circuits in a Three-Phase Circuit	33
Programmable Compact Controls	34
Electropneumatics in Automated Control	35
Programmable Logic Control	36
Multimedia-Based Automation, PLC and Bus Technology	38
Programmable Logic Control with SIMATIC S7-300	40
Networked Systems in Automation Engineering	42
AS-Interface	44
PROFIBUS DP	45
Industrial Ethernet/PROFINET	46
Remote Maintenance and Diagnostics	47
RFID	48
Image Processing	49
Operating and Monitoring	50
Open-Loop Control of Drive Systems	51
Safety Technology in Automation Technology	52
Circuitry Involving Safety Relays	54
AS-i Safety	55
PROFIsafe	56
Optical Systems	57
System Models and Process Simulation	58
Multimedia-Supported Models	60
PCB Models	61
ProTrain Process Simulation	62
PLC Universal Process System Simulator	64
Electrical PLC Process System Models	65
“Industrial Mechatronics System” IMS®	66
Sub-Systems at a Glance	68
Education towards Industrial Standards	70
Rapid Set-Up and Installation Guaranteed	71
Easy Access to Each Sub-System	72
IMS® Conveyor Belt Systems and Sub-Systems	74
IMS® Sub-Systems	75
IMS® Robot Technology	80
From IMS® Sub-Systems to IMS® Production Lines	82
IMS® – Assembly Technology	85
IMS® - for Use with All Process Control Systems	86
IMS® Aluminium Profile Trolleys	87
IMS® Virtual	88

Qualifications through Quality

Training Systems for Automation Engineering

Technical advances ...

Automation technology is becoming ever more important thanks to the rapid developments taking place in industrial process automation. Developments here are very closely integrated into other related fields such as drive technology, automatic control or computer engineering. Due to the lightning fast pace of development, automation engineering has become one of the most innovative and rapidly changing fields in electrical engineering.



... have an enormous impact on vocational training and education

New industrial solutions necessitate new training systems. Innovations in decentralisation and visualisation, the introduction of the internationally applicable IEC1 131-3 standard, and thus the uniform PLC programming of controls according to uniform rules and regulations are just a few examples of the way vocational training is being revolutionised.

The need for modern, practice-oriented training systems that can convey state-of-the-art technology and the skills needed to master them arises from the demands being made on today's automation technicians.

A strong partnership with industry

That is what provides the guarantee for a hands-on, practical application. Lucas-Nülle has found an excellent partner in market leader Siemens AG. The most modern products to be found in automation technology have been provided by Siemens AG to be modified for teaching purposes and adapted for the precise requirements of training colleges and educational institutions. All of the curriculum requirements are covered regardless of the level of difficulty from the compact basic system version all the way to modular high-end systems with field bus interface and decentralised peripherals including operating and monitoring equipment. Safety technology, too, has of course been integrated into all of the systems in conformance with the latest European guidelines pertaining to machinery. The modular and scalable training system forms the innovative and future-proof foundation for excellent and in-depth training in the area of automation engineering.



Different Systems to Fit Differing Needs

Our Objective Is to Meet Everyone's Standards

UniTrain-I

With the multimedia-based experiment and training system UniTrain-I, students are guided through the individual experiment steps of a well-structured and educationally designed course assisted by texts, graphics, animations and tests.

In addition to the training software, each course contains an experiment card that allows the practice-oriented assignments to be performed. Courses on automation engineering convey the knowledge and skills needed to understand the control, operation and maintenance of modern process automation systems. In these various courses, animations and numerous experiments on authentic systems assist the students in working their way through the fundamentals, principles and component features of automated processes and manufacturing systems.



Your benefits

- Theory and practice at the same time and the same place
- High student motivation induced by PC support and new media
- Rapid learning success thanks to well-structured course design
- Rapid comprehension of theory thanks to animation and graphics
- Technical skills trained with autonomous experimenting
- Constant feedback provided by comprehension questions and tests
- Guided trouble-shooting using integrated fault simulator
- Guaranteed safety thanks to extra-low safety voltage
- Huge selection of courses (courses on more than 100 topics available)
- Sample solutions for trainers



UniTrain-I system

- Comprehensive portable laboratory
- Multimedia courses
- High-tech measurement and control interface
- Theory and practice in conjunction



UniTrain-I interface with USB interface

- Oscilloscope with 2 analogue differential inputs
- Sampling rate 40 Msamples/s
- 9 measuring ranges 100 mV - 50 V
- 22 time ranges 1 μ s - 10 s
- 16 digital inputs/outputs
- Function generator for frequencies up to 1 MHz
- 8 relays for fault simulation



UniTrain-I experimenter

- Accommodates experiment cards
- Experiment voltage supply ± 15 V, 400 mA
- Experiment voltage supply 5 V, 1 A
- Variable DC or three-phase source 0 ... 20 V, 1 A
- IrDa interface for multimeter
- Additional serial interface for cards



Integrated measuring equipment and power supplies

- Multimeter, ammeters, voltmeters
- Dual-channel storage oscilloscope
- Function generator and waveform generator
- PROFIBUS monitor
- PROFIBUS tester
- ... and many other instruments



LabSoft training and experiment software

- Huge selection of courses
- Comprehensive theory
- Animations
- Interactive experiments with instructions
- Free navigation
- Documentation of experiment results
- Tests

Different Systems to Fit Differing Needs

Training panel system

Whether it be for conventional classroom instruction or practice-oriented student experiments, the training panel system allows teachers to employ a variety of instructional methods. The training panels consist of moulded panels, both sides of which are melamine resin painted in a dark anthracite colour. All panels are to uniform DIN A4 dimensions.

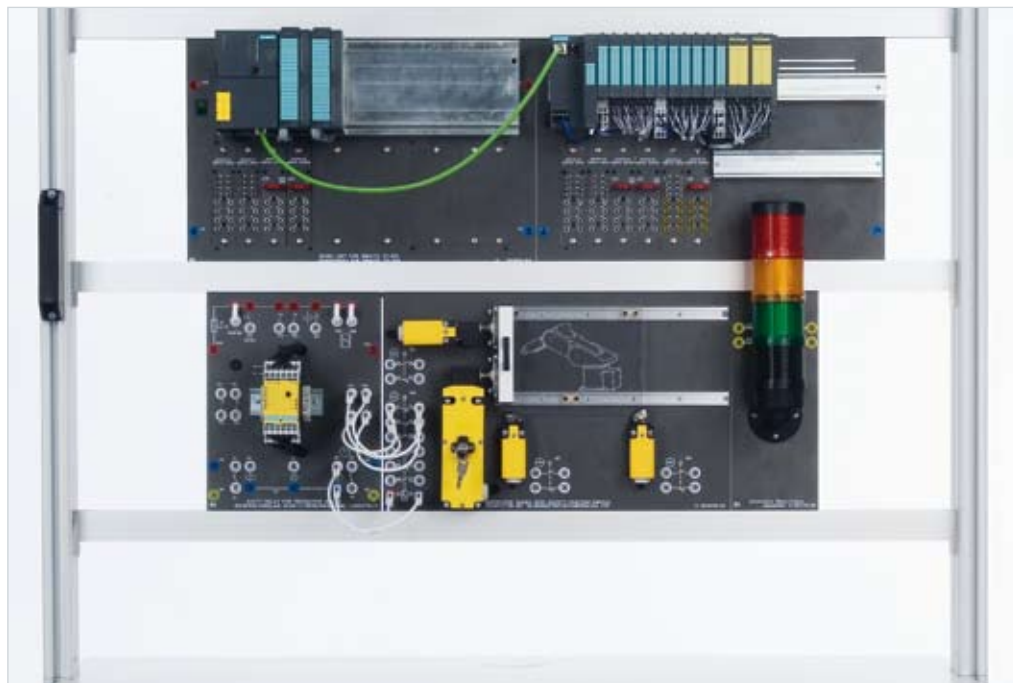

Panel system

Your benefits

- Multifaceted and flexible thanks to modular design
- Suitable for student exercises and demonstration
- Safe thanks to double insulation (safety sockets and safety cables)
- Integration of industrial components makes systems similar to industrial use
- Clear and legible front panel thanks to contrast-rich and scratch-proof printing process
- Modern instrumentation with PC connection
- Colourful experiment and technical training handbooks
- Student worksheets and sample solutions

Assembly and installation exercise system

The perfect complement for project-oriented instruction

When it comes to installation and assembly exercises it is the technical skills and workmanship that count. All of these exercises are highly hands-on and practice-oriented. The connections are carried out using industrial methods and wiring materials (mounting rails, terminal strips, screws etc.). All parts except for disposable components (such as leads) are reusable.

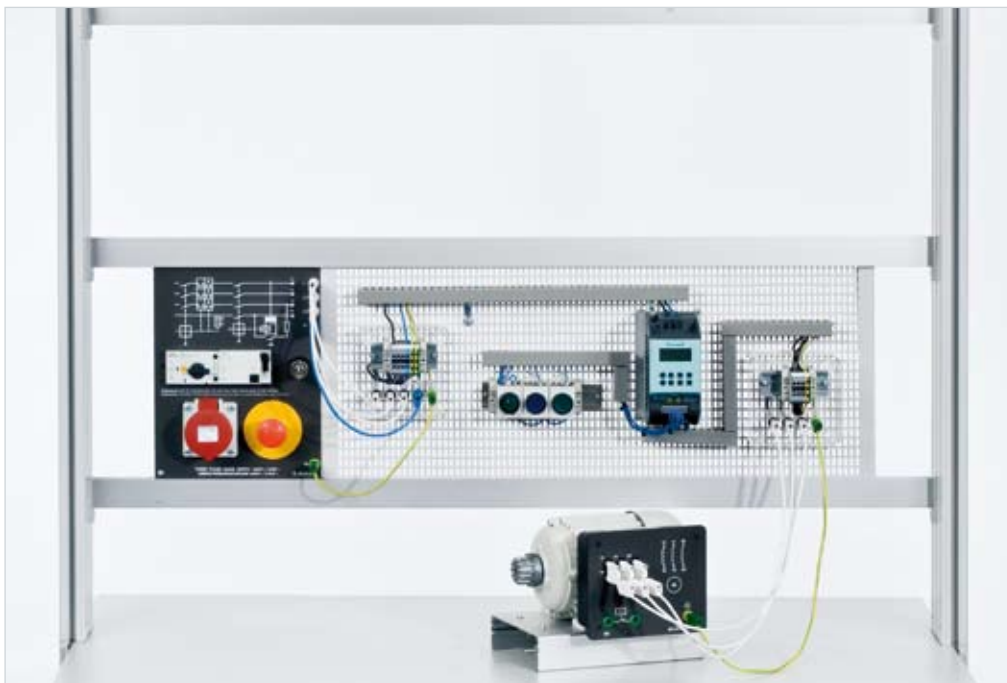

Assembly and installation exercises

Your benefits

- Plan and implement projects
- Learn connection techniques
- High degree of practical experience using industrial-type technical documentation and software
- Combinable with the training panel system
- Circuitry is implemented using industrial components
- Complete project documentation

Presenting Complex Training Content in a Vivid Way

Project-Oriented Training Media – Adaptable to All Training Systems

Manuals

These provide not only the detailed descriptions needed to set up the respective training systems but also numerous exercises, examples and projects.

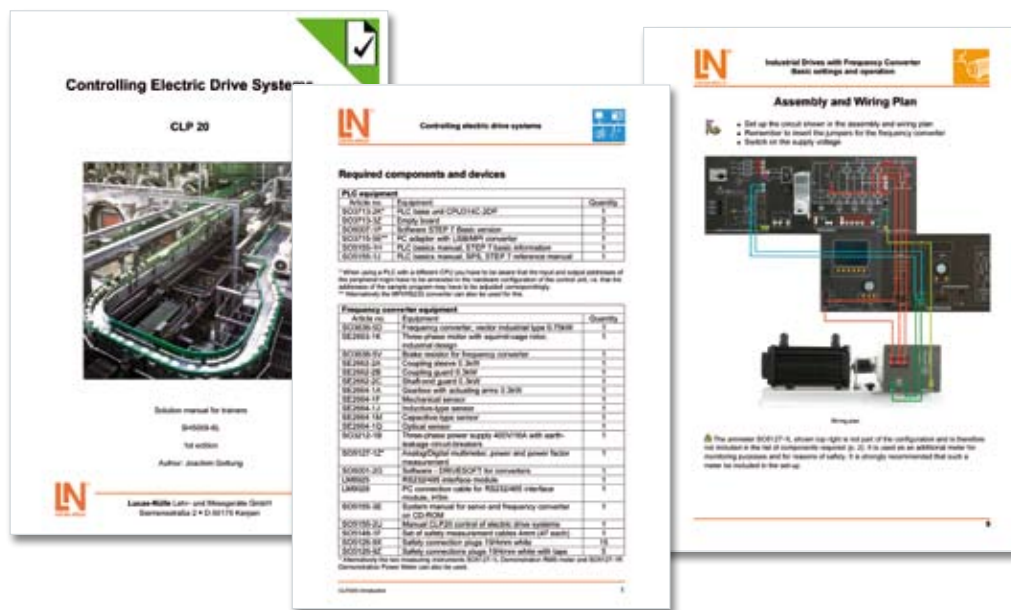

Multimedia courses

Many of the manuals are available in the form of multimedia courses. They contain features familiar from the UniTrain-I courses, such as:

- Test questions
- Interactive experiment set-ups
- Navigation bars
- Animated theory

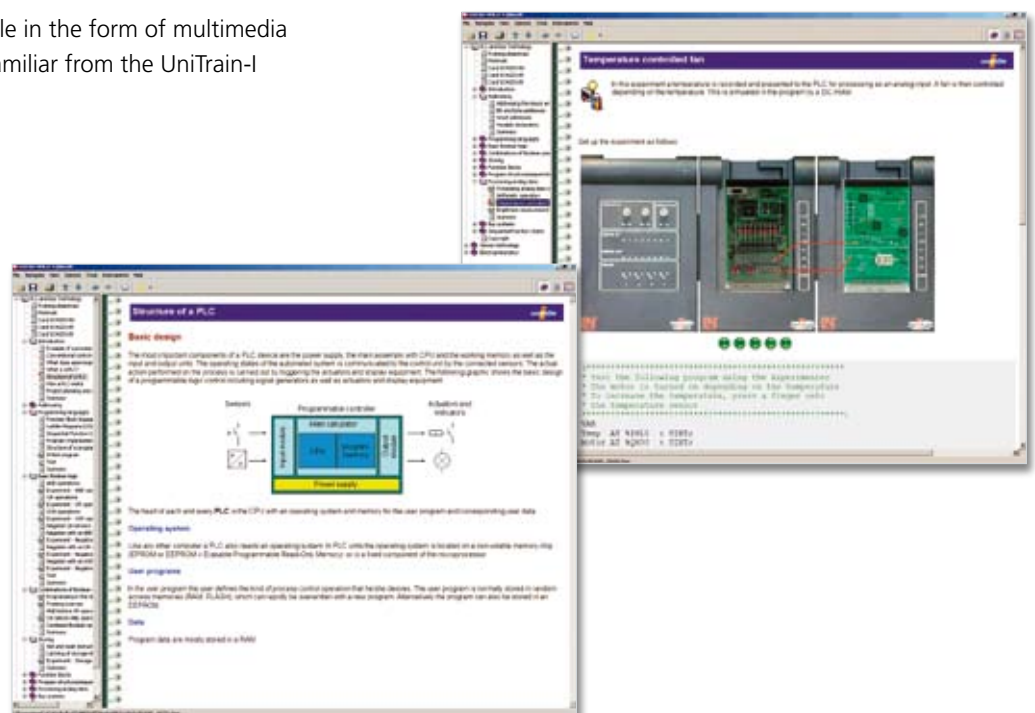

QuickCharts

These provide a quick overview of a certain subject or training area. Work steps, work processes and technical contexts are explained clearly and concisely.

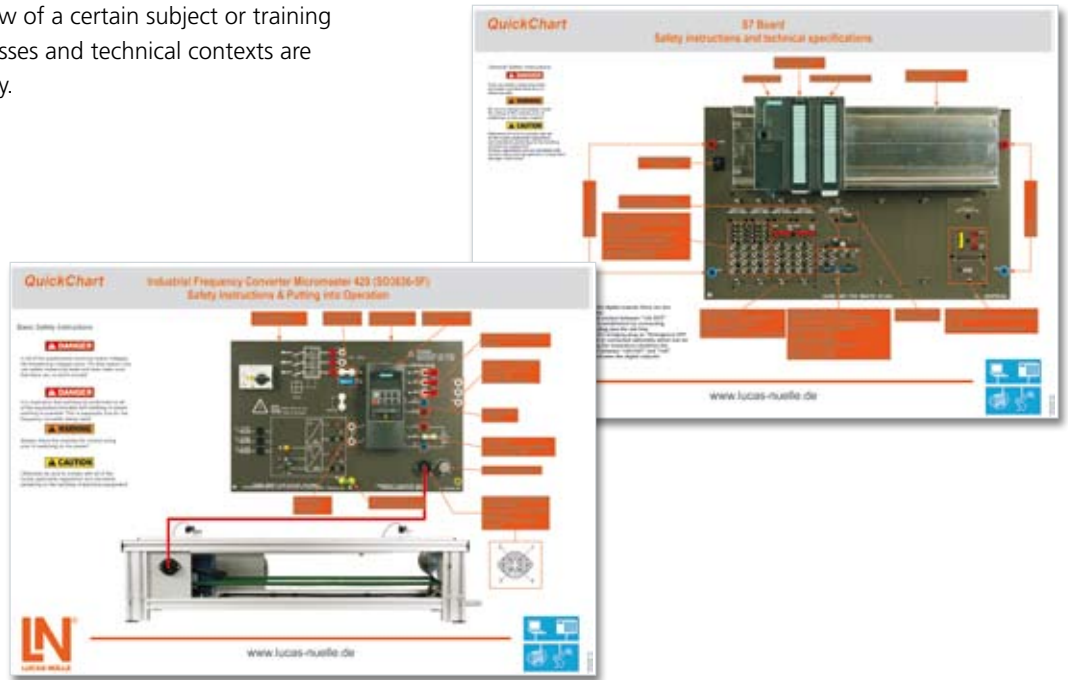

Presentation transparencies

These support your lessons with, for example, background information, block circuit diagrams, basic physics, specific standard parameters, special modifications and applications. Supplied as a CD with a set of transparencies in PowerPoint format.

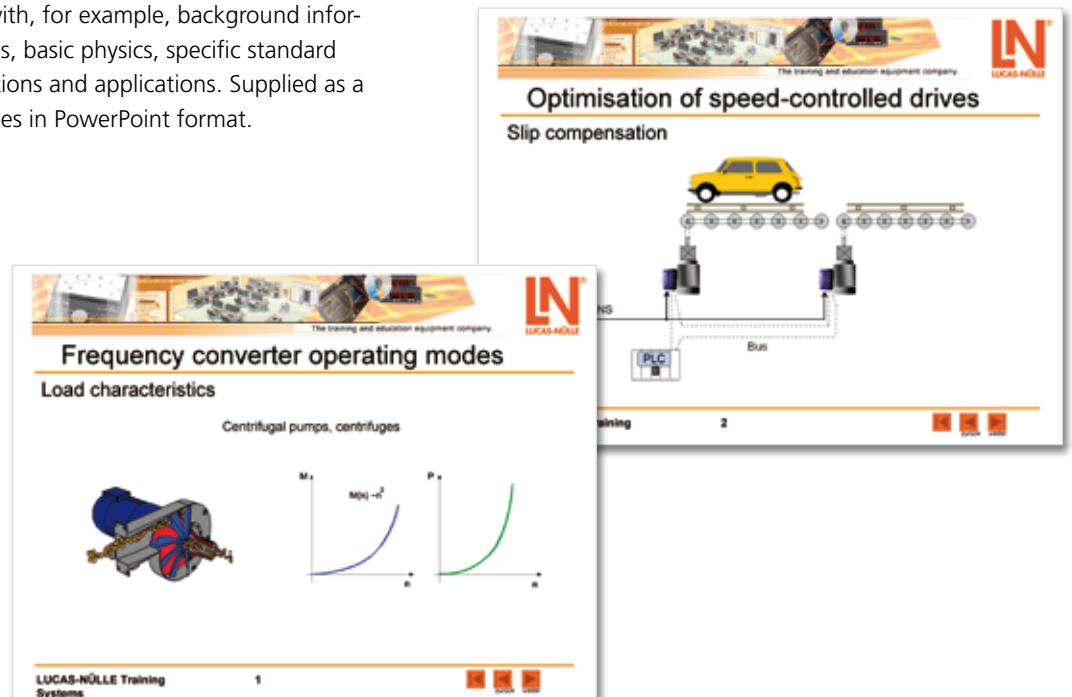

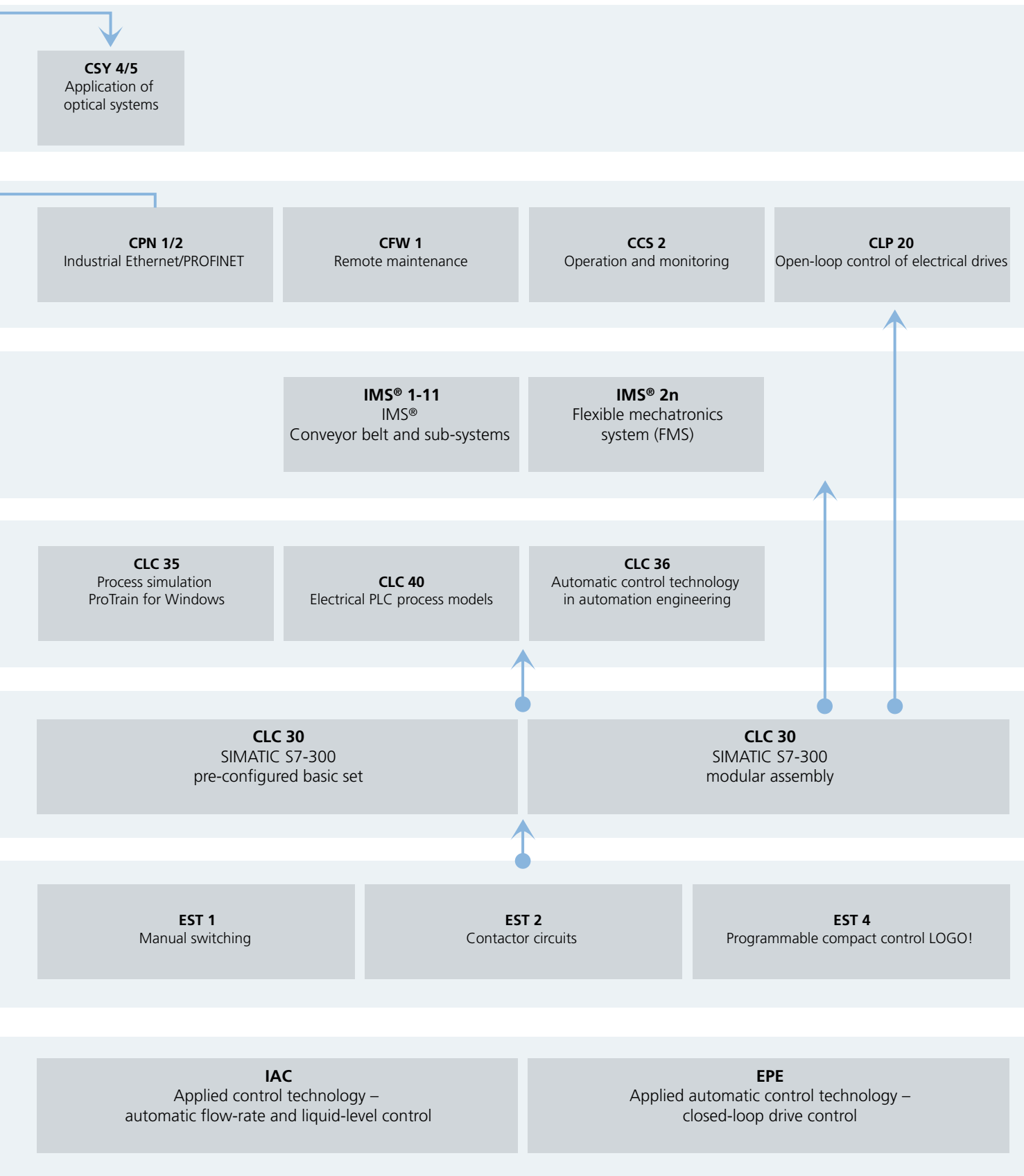

More than Just a Training System

A Total Solution – the Automation Laboratory

Presenting complex training content in a vivid way using modern training media

Simple introduction to each IMS® sub-system using multimedia UniTrain-I courses

Flexible production systems with IMS®



**Complete solutions for process control systems:
PLC, AS-i, PROFIBUS, PROFINET, HMI, remote maintenance,
safety technology, drive technology**

**The system models and process simulators
offer a multitude of control assignments**

**With UniTrain-I, multimedia is used
to develop know-how and skills**

Instrumentation and Automatic Control Technology

Instrumentation

The measurement of analog, non-electrical variables is of critical importance and is basic to all areas of automation engineering. After all, it is the detection of the physical variable and its conversion into electrical signals which makes the automatic control of a system possible in the first place.

Automatic Control Technology

Using the automatic control technology training system, the student is not only introduced to the basics but also gains insight into more advanced areas in a graphic and practice-oriented way. In the process, modern training systems, such as digitally operating controllers and multimedia-based training systems, are used to convey practical skills and competence to the trainees.



Sensor technology

Automation and closed-loop control technology is based on the detection of the physical operating states of a process and the variables which have an effect on it. This is performed by a wide range of sensors that operate according to different physical principles. For that reason, knowledge of sensor technology is indispensable for anyone who has anything to do with automation or automatic control technology, and that means the mechatronics specialists, too.



Closed-loop control technology in automation

Closed-loop control technology is of paramount significance for modern technical systems. Optimised control loops assist in production and process engineering, in order to efficiently exploit resources such as energy and raw materials and to ensure product quality. Furthermore, by integrating closed-loop control technology it is possible to develop innovative and intelligent products, a prerequisite to global competitiveness.



Source: Thyssen Krupp

Training systems

Our training systems cover the following subjects:

- Sensor technology
- Instrumentation
- Automatic control technology



Sensor Technology in Automation

Industrial Sensors

Sensors are needed for the open-loop control of technical processes using programmable controllers. They convert physical variables into electrical output signals and assume the function of the human senses. As such, sensor technology is fundamental to this field and indispensable for any automation technician.



UniTrain-I course "Sensor technology in automation"

UniTrain
SYSTEM

Training contents

- Working with capacitive and inductive proximity switches
- Working with various types of sensors such as magnetic field or optical sensors
- Exploring which sensor responds to which material
- Determining the switching gap, hysteresis and operating frequency
- Methods of testing various materials using sensors driven electrically along the X-axis

Measurement of Electrical Variables

Current/Voltage – Power – Work – Frequency

The introduction to electrical measurement techniques is based on moving-iron and moving-coil galvanometers. Here the instruments are used to measure voltages and currents, to work out the effect of the characteristic response on the measurement result, and to expand the measurement range using additional resistors.



UniTrain
SYSTEM

UniTrain-I course "Measurement of electrical variables"

Training contents

- Power measurement
- Elaboration of measurement principles using DC circuits
- Working through the differences between active, apparent and reactive power measurement in simple experiments on an AC circuit
- Measurement and explanation of power factor
- Load measurements and measurement of electrical work with the aid of a Ferraris meter

Measurement of Non-Electrical Variables

Temperature – Pressure – Force – Torque

In modern day industrial practice it is becoming more and more a necessary to monitor, display or electronically process physical variables. To do this, you have to use the appropriate tools to convert non-electrical variables into electrical ones.



UniTrain-I course "Measurement of non-electrical variables TPF"

UniTrain
SYSTEM

Training contents

- Elaboration of the influence of measurement circuits
- Characteristics of different temperature sensors: NTC, Pt 100, KTY, thermocouples
- Pressure measurement: piezo-electric, inductive and resistive pressure sensors
- Principle of force measurement with strain gauges applied to bending bars and torsion rods
- Recording characteristics for different sensors
- Methods for linearising non-linear characteristics
- Identifying possible fault sources

Measurement of Non-Electrical Variables

Displacement – Angle – Speed

In mechatronics or drive-technology applications found in manufacturing, the rapid and precise detection of such variables as displacement, angle and speed are critical for the system's dynamic response, efficiency and quality.



UniTrain-I course "Measurement of non-electrical variables ssn"

UniTrain
SYSTEM

Training contents

- Analog and digital methods used for displacement, angle and speed measurement
- Introduction to the required sensors, their operation and characteristics
- Experiment-based determination of characteristics
- Calibration and measurement circuitry
- Experiments with capacitive and inductive-type sensors
- Use of optical sensors and Hall sensors for detecting the position of rotating shafts
- Performing incremental, BCD and Gray code encoder displacement measurement
- Performing investigations on rotating shafts using a resolver

RLC Measurement

Resistance – Inductance – Capacitance

Bridge and impedance measurement methods have been used for years in bridge measurement circuits to determine the parameters of passive components such as resistors, capacitors and inductors.



UniTrain
SYSTEM

UniTrain-I course "RLC measurement"

Training contents

- RLC measurement is performed using calibrated examples of the following:
 - Wheatstone bridge
 - Maxwell-Wien bridge
 - Wien bridge
- Elaboration of measurement principles
- Measurement with an RLC meter
- Comparison of measurement results

Practical Introduction to Automatic Control Technology

Closed-Loop Temperature – Speed – Light – Flow-Rate Control

In the age of automation, automatic control technology is of paramount importance in modern technical systems.



UniTrain
SYSTEM

UniTrain-I course "Practical introduction to automatic control technology"

Training contents

- Operating principles of open-loop and closed-loop control
- Design and operation of continuous and discontinuous controllers
- Hands-on investigation of control loops with continuous controllers
- Automatic temperature control of a sauna with 2-position controller
- Design and optimisation of an automatic speed control with continuous controllers
- Control response to set-point changes and disturbance response of a light control loop
- Automatic flow-rate control with 2-position controller and PI controller (requires optional "liquid-level" controlled system model)

Analysis of Control Loops

Control Loop Elements – Continuous Controllers – Discontinuous Controllers – Closed Control Loops

A basic understanding for the operational response of different controller types and controlled systems in the time and frequency domains is decisive for selecting the right controller and getting reliable control loop operation.



UniTrain
SYSTEM

UniTrain-I course "Analysis of control loops"

Training contents

- Recording the step responses to determine the response and characteristic values of various control loop elements such as:
 - P-action elements
 - I-action elements
 - Two PT1 elements
 - Non-linear elements
 - Arithmetic elements
- Exploring appropriate controller types
- Optimising closed control loops
- Analysis of control loops and controlled systems using Bode diagrams
- Static and dynamic responses of control loop elements and closed control loops

Design and Optimisation of Controllers

Real Controlled Systems – Optimisation Guidelines – Controller Optimisation – Stability Analysis – Numerical and Fuzzy Control

These equipment sets supplementary to the “Analysis of control loops” course using real controlled systems provide graphic and more advanced, in-depth understanding of automatic control technology.

Fuzzy control is needed to regulate complex measurement variables and non-linear systems. Such fuzzy systems can be integrated into the automatic control components of the UniTrain-I system by adding a supplementary software package.



UniTrain-I course “Design and Optimisation of Controllers”

UniTrain
SYSTEM

Training contents

- Determine the parameters of real controlled systems:
 - Temperature-controlled systems
 - Speed-controlled systems
 - Light-controlled systems
- Observe system response with continuous and discontinuous controllers in a closed control loop
- Investigate the control response to set-point change and disturbance variables
- Perform design and optimisation in the time and frequency domains
- Assessment of control quality and stability analysis in the frequency domain by plotting a Bode diagram, i.e. locus curve
- Numerical and fuzzy control:
 - Simulation of control loops on a PC
 - Real-time control using a PC
 - Investigation of a fuzzy controller
 - Automatic fuzzy control of real controlled systems

Applied Automatic Control Technology

Closed-Loop Liquid-Level Control – Flow-Rate Control

The “Automatic liquid-level control” system is an applied control technology experiment designed specifically for training and real-life applications. The compact training unit contains a liquid reservoir, a pressure transducer to detect the actual liquid level as well as a reserve tank including pump. To achieve constant pumping power, a secondary control loop with a flow-rate meter is integrated, although it can also be disconnected. Disturbance variables can be simulated using adjustable throttle valves, which modify the inlet and outlet flows at the liquid reservoir. As an option, a second liquid reservoir can be included to assemble a controlled system with time delays of the second-order time delays.

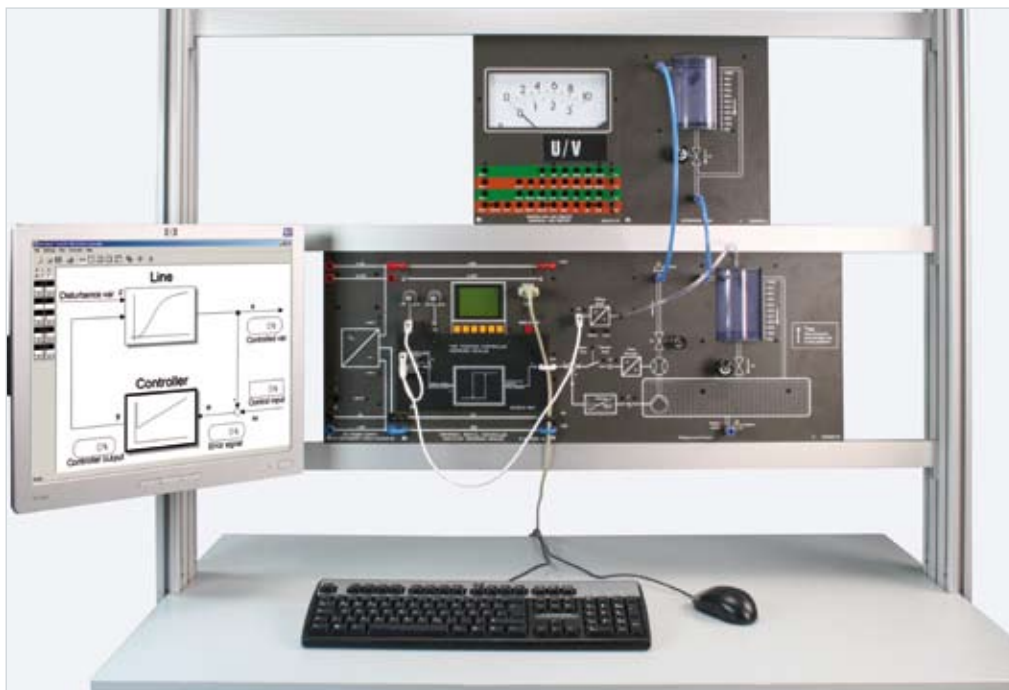

Experiment example “Automatic liquid-level control IAC 10”

Training contents

- Parameters of controlled system
- Design and function of closed control loop
- Two-position controller in an integral-action controlled system
- Two-position controller in a controlled system with higher order time delay
- Automatic liquid level-control with continuously operating PI/PID controller
- Automatic liquid level-control with secondary flow-rate control loop
- Automatic liquid level-control in a system with higher order time delay
- Disturbance response of control loop

Digital Universal Controller

As we have already seen in industry, conventional analog controllers are now being replaced by digital controllers, even in the areas of training and education. Besides the enhanced precision and the ease with which parameters can be set, digital controllers also offer excellent capacity for being integrated into the process control and process visualisation level via communications interfaces or bus technology. The digital universal controller combines the functionality of an industrial-type digital controller with capacity for integration into an educationally designed and proven training system covering the entire field of automatic control technology. The training system is supplemented by specially designed overlay masks, used to conceal all but the functions required for the application in question, as well as software packages for the optimisation of the control loops using the PC.



Digital universal controller with overlay masks

Software packages

- Software for the investigation of controllers
- Software for two-position controllers
- Software for three-position controllers
- Software for PID controllers
- Software for four-quadrant drive controllers

Applied Automatic Control Technology

Static Converters with DC Motors

The static converter equipment sets can be expanded into converter drives at minimum added cost simply by adding the corresponding electrical machine. The digital controller then transforms this assembly into an automatically controlled drive. To investigate the drive under load in four-quadrant operation mode all you need is a servo brake.

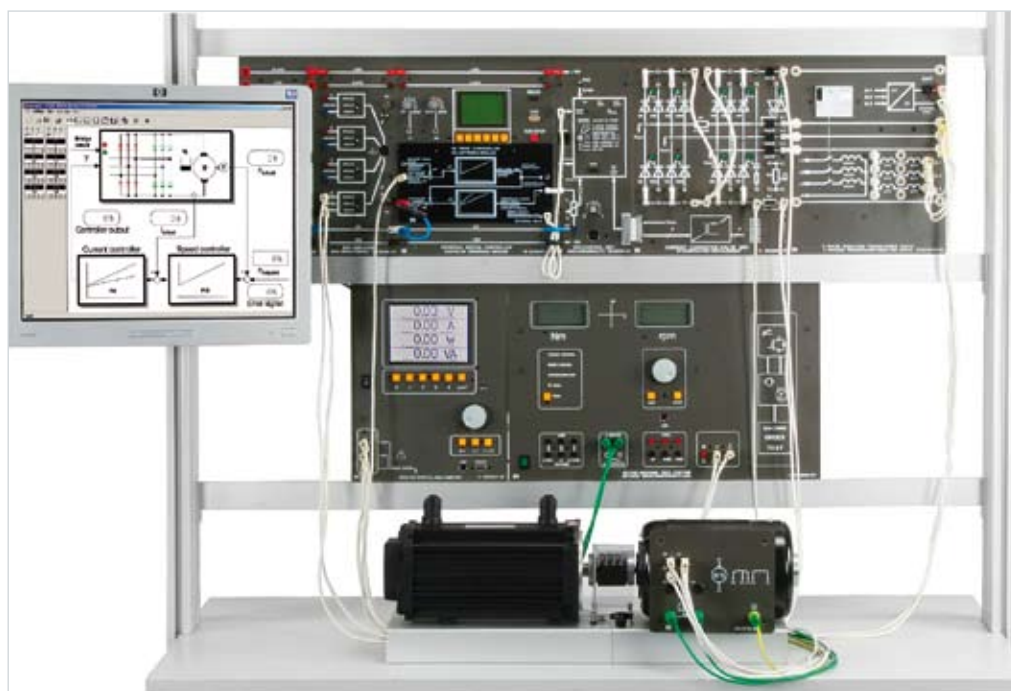

Experiment example "Closed-loop speed control of a DC motor EPE 11"

Training contents

- Closed-loop speed control in single- to four-quadrant operation with and without secondary current control loop
- Speed control with single and double converters or IGBTs
- Four-quadrant mode, power recovery
- Automatic speed control, current control, cascade control, adaptive control
- Computer-assisted system and controller analysis, parameter setting
- P, PI, PID control
- Optimisation of controller
- Response of automatically controlled DC motors with line-commutated static converters (EPE 11)/ self-commutated converters (EPE 21)

Automatic Control Technology in Automation Engineering

One Model – Two Functions: Automatic Liquid-Level and Flow-Rate Control

Due to the fact that the controlled variable, that is to say the level of liquid, is immediately visible, this experiment is a particularly graphic one and thus eminently suitable for an introduction to automatic control technology. The compact training unit contains a liquid reservoir and a pressure transducer to determine the actual liquid level, as well as reserve tanks including a pump. Disturbance variables can be simulated using adjustable throttle valves which modify the inlet and outlet flows at the reservoir.



Experiment example "Liquid-level controlled system CLC 36"

Training contents

Automatic liquid-level control

- Assembly, calibration and optimisation of a liquid-level control loop with variable system characteristics
- Two-position controller in an integral-action system and a controlled system with higher order delay
- Two-position controller with delayed feedback in a liquid-level control loop
- Two-position controller with float switch
- Automatic liquid-level control with disturbance variable forward feed and pre-control
- Second-order time delay controlled system with optional supplementary tank

Automatic flow-rate control

- Assembly, calibration and optimisation of a flow-rate control loop connected to a liquid level controlled system
- Principle, response and deployment of flow-rate measurement
- Investigation of closed-loop flow-rate control response to disturbance variables and set-point step changes

Industrial Installation Technology

The Challenge: Rapid Data Monitoring for Processes

Modern industrial installation is making very high demands on the abilities of electricians. Reading complex circuit diagrams, selecting the appropriate equipment, calculating figures for the necessary safety mechanisms and the programming of control units are just some of their everyday activities.



Electropneumatics

Use of compressed air to transmit power has become more and more attractive as time goes on. The advantage of pneumatics is that actuators are simple and cost-effective to design and implement, for example, in the form of pneumatic cylinders. In contrast to purely pneumatic controls, electropneumatic units permit the implementation of considerably more complex functions, particularly through the use of electronic circuits such as programmable logic controls, for example.

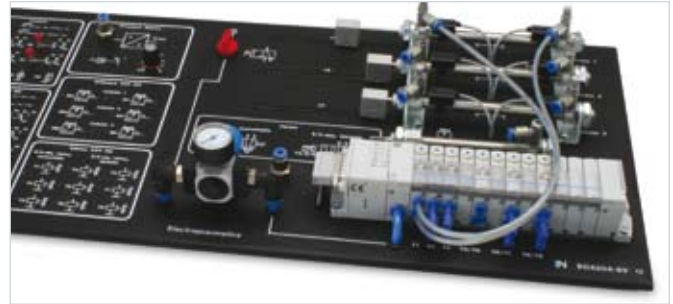

Installation technology

The new compact boards constitute a cost-effective complement to the comprehensive, modular experiment systems used in process control technology.

By including additional function elements and allowing various teams to work in conjunction, it is possible to achieve excellent results in comprehensive projects over a longer period of time.

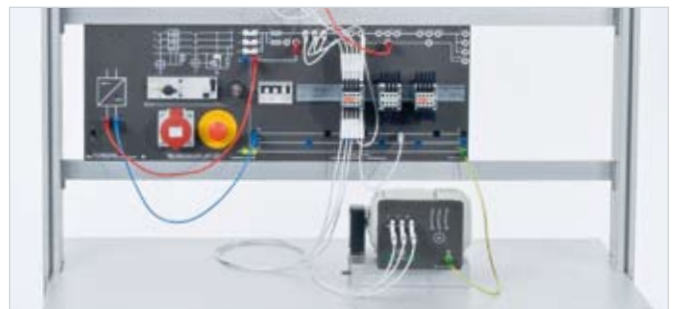

Training systems

In order to fulfil all of these demands, the training systems cover the following topics:

- Direct switching in three-phase circuits
- Contactor circuits in three-phase circuits
- Complex process system circuitry
- Programmable mini controls
- Electropneumatics in automation technology



Manually Operated Switches in a Three-phase Circuit

Practice-Oriented Training in Process Control Technology

The development of circuits and the appropriate choice of circuit elements and equipment lie at the focal point of this training segment. Multi-pole loads can be connected directly into a three-phase circuit up to a specified power class. To accomplish this there are corresponding switching devices, which may be deployed differently depending on the application.



Experiment example "Manually operated switches in a three-phase circuit EST 1"

Training contents

- Manual switching in a three-phase circuit
- Contactor circuits in a three-phase circuit
- Programmable mini controls
- Switch-off for a three-phase induction motor with squirrel-cage rotor
- Star-delta circuit for a three-phase induction motor with squirrel-cage rotor
- Star-delta reversing circuit for a three-phase induction motor with squirrel-cage rotor
- Three-phase induction motor with Dahlander pole-changing circuit
- Three-phase induction motor with two separate windings and pole-changing circuit

Contactor Circuits in a Three-phase Circuit

Switching Large Loads On and Off

Above a certain power class it is no longer possible to switch three-phase loads directly on line. For that reason, loads are indirectly activated using contactor circuits of the most varied of types. The development of the control circuit and the design with function control form the focal point of this training unit. Together with the supplementary equipment sets, additional more extensive control operations can be handled. The supplementary machine set contains the machines and equipment units needed to test the circuits for direct and indirect control of motors connected into the three-phase circuit.



Experiment example "Contactor circuits in a three-phase circuit EST 2"



Supplementary equipment set

Training contents

- Drawing a circuit diagram
- Setting a motor protection relay according to the motor's rating plate
- Contactor circuitry with self-latching
- Switch-on delay relays and drop-out delay relays
- Pulse contactor circuit
- Reverse contactor control with interlocking
- Limiting control with mechanical limit switches and rotation reversal
- Star-delta circuits
- Function testing and fault finding
- Three-phase motor connection
- Protective, safety and switch-off functions
- Project planning, construction and commissioning of complex controls

Programmable Compact Controls

Ideal Introduction to Process Control Assignments

The initial foundation stones for the programming of compact control systems were built on classic process control and digital technology. These exercises serve as preparation for training in automation technology. The compact controllers are equipped with their own displays. Programming can be carried out without the need for an additional PC.



Experiment example "Programmable LOGO! compact controller EST 4"

Training contents

- Programming logic functions
- Programming timing elements
- Complex control tasks
- PC programming, visualisation and documentation of an application

Electropneumatics in Automated Control

Pneumatic Cylinders – Directional Control Valves – Process Control Elements

Use of compressed air to transmit power has become more and more attractive. Pneumatic systems are frequently being used for such tasks as transport, drilling, grinding, winding, sorting, and open- and closed-loop controls. This can be attributed to the fact that in some automation tasks there is simply no better or more efficient tool that can be used.



UniTrain
SYSTEM

UniTrain-I course "Electropneumatics"

Training contents

- How single- and double-acting cylinders work
- Familiarisation with various directional control valves
- Operation and design of electropneumatic controls
- Hard-wired controls
- Programmable controls
- Recording displacement/time graphs
- Time-dependent controls

Programmable Logic Control

An Integral Component of Automation Engineering

New focal points in training and education reflect new skills and qualifications in the disciplines of process control technology, electro-mechanics, electronics and computer-assisted control systems (PLC). The basics of PLC technology as well as how it works are graphically demonstrated using examples, explanatory texts and practical exercises.



Multidisciplinary applications

Nowadays, programmable logic control systems are an integral part of automation engineering. They are used, for example, to control automated processes in the machine industry, for transport and conveyor belts, process engineering, drive systems and in manufacturing plants.



Time to provide individual support

Basic topics are taught using the UniTrain-I "Automation Engineering" program. The self-study aspect of the courses means instructors have more time to provide personal attention to individual students or small groups. With the UniTrain-I PLC control system, students get hands-on training using realistic control tasks and assignments in line with industry standards.



Training systems

The training systems focus on conveying basic knowledge and information on programmable logic control (PLC) and demonstrate how such systems are networked with sensors and actuators. The fundamentals and operation of PLC systems are graphically explored using a multitude of examples, explanations, exercises and practical assignments:

- UniTrain-I PLC and bus technology
- Programmable logic controls with SIMATIC S7-300



Multimedia-Based Automation, PLC and Bus Technology

Programmable Logic Control (PLC)

Today's highly automated industrial landscape is characterised by machines which operate more or less automatically. As a rule these systems are operated by programmable logic control. Developments are leading to more decentralised control systems utilising field bus systems.



UniTrain
SYSTEM

Training contents

- Introduction to the fundamentals and basic concepts of PLC systems and how they operate
- Introduction to PLC programming
- Implementing logical operations from storage elements all the way to more complex networks
- Programming of times, counters and self-written functions
- Designing a traffic light circuit
- Conversion of non-electrical measurement variables to electrical signals
- Programming with Instruction List (IL) and Structured Text languages using an editor in compliance with IEC 1131-1
- Programming in Function Block Diagram (FBD), Ladder Diagram (LD) and IL languages with STEP 7

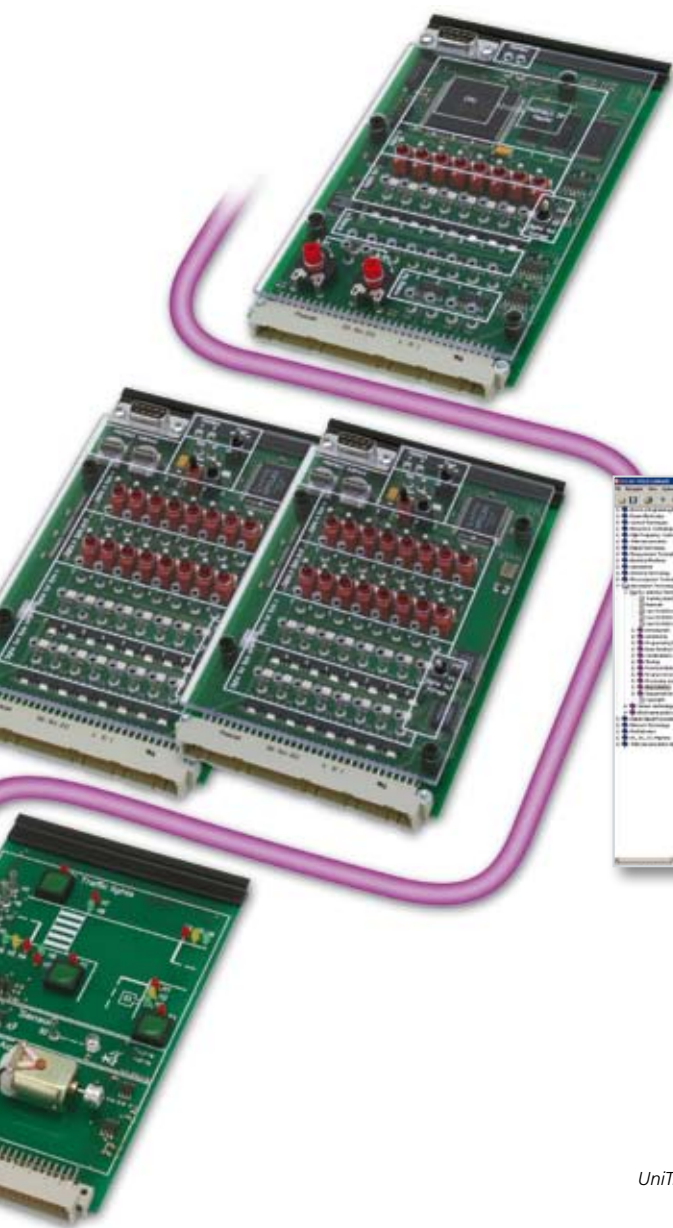

Field Bus Systems – PROFIBUS

A PLC controller alone is no longer seen as the central unit of an automated system. Complete automation solutions now integrate sensors, drives and other actuators as well as the components used for system operating and monitoring. Using standardised field bus systems, it is possible to fully integrate a variety of different systems, for example.

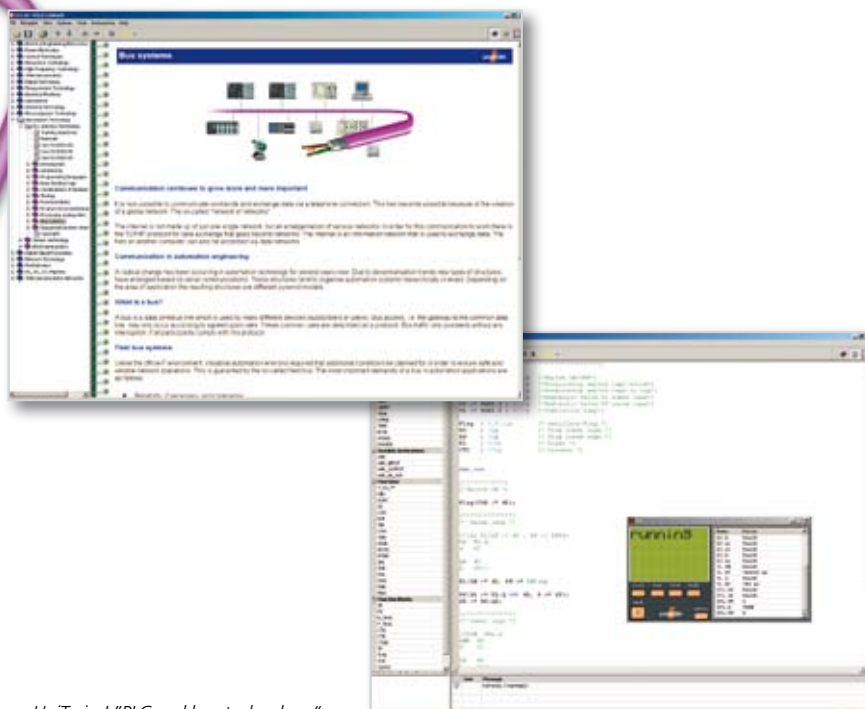

UniTrain-I "PLC and bus technology"

Training contents

- Operating decentralised peripherals using a network with PROFIBUS DP master and slaves
- Programming and configuration of a field bus using special software tools, such as PROFIBUS Monitor and PROFIBUS Tester
- Data transmission structures and protocols
- Transmission and fault analysis

Programmable Logic Control with SIMATIC S7-300

Fully Configured Basic Equipment Sets

In addition to the recommended basic set, all of the CPUs in the 300 series are available as fully configured units. To implement automation assignments comparable to those actually used in industry, the STEP 7 software package is employed. The system features object-oriented programming of automation units in line with the IEC 1131-1 standard. Editors are also available for the languages LD (Ladder Diagram), FBD (Function Block Diagram), IL (Instruction List), ST (Structured Text, designated Structured Control Language, SCL, in STEP 7) in addition to the GRAPH tool (for Sequential Function Chart programming) plus tools for software testing and hardware configuration.



Experiment example "SIMATIC S7-300 CLC 30"

Training contents

- Design and project configuration for a PLC
- Creating assignment lists
- Programming in accordance with IEC 1131-1 (IL, LD, FBD, ST/SCL, GRAPH) using STEP 7
- Programming of binary and word operations
- Programming of counters and timers, comparison and arithmetic functions
- Program structure, calling subroutines
- Commissioning, testing and fault finding on an automation system
- Diagnostic functions
- Documentation and archiving

Custom Control SIMATIC S7-300

The training system is an industrial unit with state-of-the-art PLC control and is modularly designed for training purposes. The training system can be configured and expanded in accordance with individual preferences. Thanks to the integrated system bus input and output modules with safety sockets, it can easily be connected up and input simulations added. The training system can be expanded from the basic version all the way to a high-end system using a PROFIBUS DP interface and decentralised peripherals.



Experiment example "SIMATIC S7-300 CLC 31"

Training contents

- Design and project configuration for a PLC
- Creating assignment lists
- Programming in accordance with IEC 1131-1 (IL, LD, FBD, ST/SCL, GRAPH) using STEP 7
- Programming of binary and word operations
- Programming of counters and timers, comparison and arithmetic functions
- Program structure, calling subroutines
- Commissioning, testing and fault finding on an automation system
- Diagnostic functions
- Documentation and archiving

Complete Solutions for Automation Systems

Open-Loop Control with AS-Interface, PROFIBUS and PROFINET

Present day trends in automation engineering are heading towards modular systems with distributed systems. PROFINET, PROFIBUS and AS-Interface offer all of the networking possibilities for various intelligent components – from the lowest field level up to and including process control and instrumentation. Any components needed to operate and monitor machines (HMI) are integrated into this bus environment and permit a high degree of process transparency.



Wiring and maintenance

In order to dramatically reduce wiring and maintenance work on production lines, standardised field bus systems are increasingly being used to couple components together. This enables decentralised organisation of automation equipment, i.e. in close proximity to the actual sensors and actuators in the field. This eliminates the need for complex and error-prone parallel wiring of such actuators and sensors.



Field bus level

Thanks to standardised and open field bus protocols, systems stemming from different manufacturers are able to communicate. All automation components, including PLC systems, PCs, operating and monitoring equipment, as well as sensors and actuators themselves can all exchange data via the field bus. In order to meet demands for real-time process automation, field bus systems operate with very high data rates.

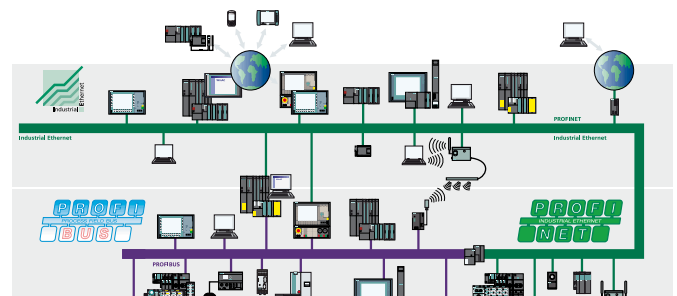

Training systems

The training systems cover all areas of control systems from simple bus structures to complex networks. One key benefit is common to all the systems and that is their rapid set-up times. By using typical industrial components, bus structures can be modified and expanded with a high degree of flexibility. Human Machine Interface (HMI) technology is naturally included as well.

The following network systems can be integrated:

- AS-Interface
- PROFIBUS
- PROFINET
- Industrial Ethernet



AS-Interface

Open Standard

With the actuator-sensor interface AS-i only a single unshielded two-wire line is needed to connect the control unit to all of the sensors and actuators. The system can be assembled in an easy and straightforward manner. Furthermore, an entire system with an actuator-sensor interface can be assembled using the AS-i communications module as master and the AS-i slaves.



Experiment example "AS-Interface CAS 1"

Training contents

- Installation and wiring of AS-Interface stations (master/slaves)
- Addressing AS-Interface stations and operating them in a bus structure
- Development and analysis of application programs
- Assembly, programming and analysis of control circuits
- Using the AS-Interface address and diagnostic unit

PROFIBUS-DP

Connecting Up Complex Systems – PROFIBUS DP

PROFIBUS DP is well established in industry and is a very realistic hands-on application for trainees in automation engineering. The fundamentals of this system are conveyed in a graphic and practice-oriented manner using the UniTrain-I "Automation engineering" multimedia course.



Experiment example "PROFIBUS-DP CDP 1"

Training contents

- Field bus systems in automation engineering
- Bus architecture, access methods, interfaces, telegram structure, fault recognition, diagnostics capability
- Assembling PROFIBUS networks and putting them into operation
- Connection of various PROFIBUS stations (master/slaves)
- Integrating PROFIBUS stations with GSD files
- Transmission, testing and fault-finding analysis on PROFIBUS
- Centralised operation and monitoring of decentralised systems

Industrial Ethernet/PROFINET

Continuous Communication with PROFINET

Ethernet has established itself as the communications standard in the office world. Demands being made on industrial communications are growing and include needs such as real-time capability, integrated decentralised field equipment or industrial-type installation technology. These requirements are met by PROFINET, an open and non-manufacturer-specific Industrial Ethernet standard, which guarantees fast and unimpeded communication from the office world to the field level. The supplement designated CPN2 "Industrial Wireless Local Area Network (IWLAN)" permits a reliable transmission of data without cables.



Experiment example "PROFINET CPN 1 with IWLAN CPN 1/2 supplement"

Training contents

- Fundamentals of network technology and practical application based on experimenting
- Data transmission via TCP/IP
- Project planning and programming of I/O devices
- PROFINET and PROFIBUS in an automation cell
- Diagnostics
- Real-time communication for automation assignments
- Implementation of IWLAN radio engineering

Maintenance and Diagnostics

Automation Engineering Online – Long-Distance Maintenance via Internet

With the training system "Remote maintenance and diagnostics", trainees can become familiar with practical skills in remote diagnosis of an automation system using a web server and system function components (SFCs). Furthermore, this training system can be used to teach network setup and assembly using PROFINET. It is the objective of the project to explore industrial components and methods of long-distance maintenance using the Internet.



Experiment sample "Remote maintenance CFW 1"

Training contents

- Utilising IT functionality in remote diagnosis
- Malfunction reporting, long-distance intervention and maintenance
- Calling up status information on the network's operating status
- Carrying out corrections in the user program
- Text messages via e-mail using SIMATIC controller
- PROFINET diagnostics

RFID

RFID chips as product IDs

Standing for Radio Frequency Identification, RFID involves contactless identification and localization of objects and permits automatic registration, storage and networking of digital data.

The „RFID“ training system is a practical environment for learning how pallets at an automation facility are identified by means of system function modules (SFC). The system can also be used to provide instruction in network configuration by means of PROFINET.



Experiment example "CID 1"

Training contents

- Writing and reading RFID tags
- Using various RFID modules
- Fundamentals of network technology and practical applications using experiment setups
- Data transmission with TCP/IP
- PROFINET
- Diagnostics

Image Processing

Vision sensor – detecting every single detail

Ideal for checking small parts for correctness, intactness and proper positioning, this image processing system can be used without a need for acquiring any specialized know-how beforehand. Designed for easy operation, the package comprises a lighting system, evaluation unit, sensor and cables.

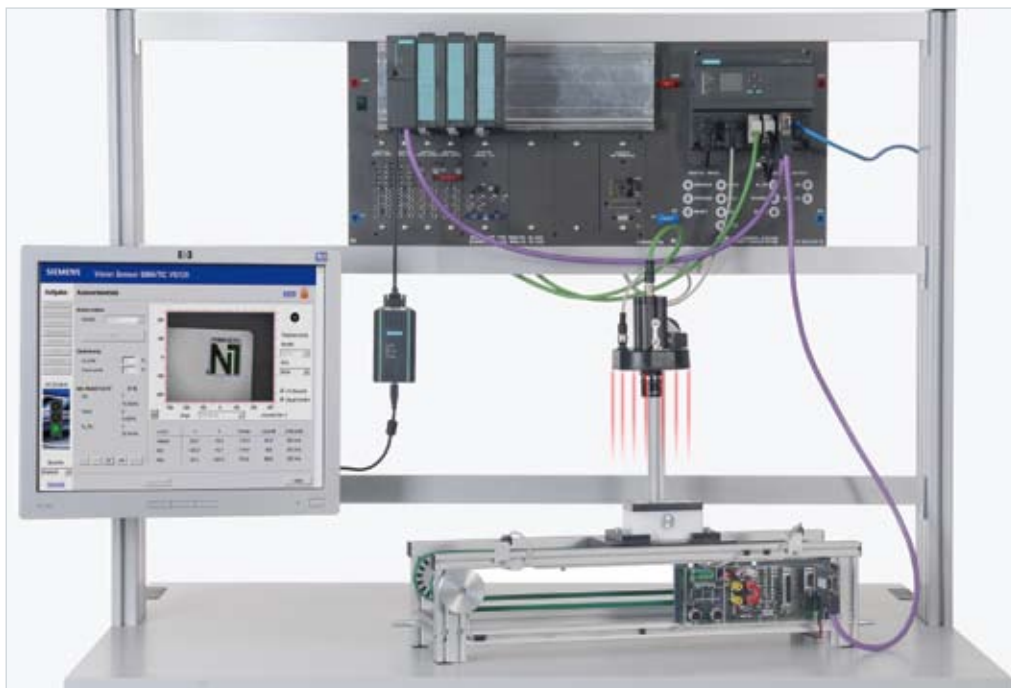

Experiment example "CVS 1– Image processing"

Training contents

- Commissioning through „training“ instead of programming
- Standalone operation
- Linkage to PROFIBUS DP / PROFINET
- WinCC integration
- Remote diagnostics
- Fundamentals of network technology and practical applications using experiment setups

Operating and Monitoring

Simplifying the Complex – HMI

Processes are becoming multi-layered and demands for greater functionality of both machine and system are on the rise. Anyone having to operate a machine today has plenty to keep an eye on. The biggest boon in this area is the Human Machine Interface (HMI). The importance of this technology is growing day by day. Operating and monitoring are synonymous with process mastery, availability and productivity.

The training systems provide the opportunity to gain insight into HMI technology. From simple text display to operator panel, through to PC-based HMI software, this system is able to tap the full potential of this technology.



Experiment example "Operating and monitoring CCS 2"

Training contents

- Project planning and commissioning of HMI equipment
- Programming fault and status messages
- Programming input and output variables
- Intervention in a control program (e.g. set-point changes)
- WinCC Flexible visualisation software

Open-Loop Control of Drive Systems

Close Relationship between Drive and Automation Engineering

The main focus of this training system lies in project planning and programming the PLC and operator panel as well as putting a frequency converter into operation and setting its parameters via PROFIBUS DP. The training system employs a servo brake to subject the frequency converter-controlled drive machine to a load. This enables various working machines such as a fan, winding drive, calendar, compressor and a flywheel to be simulated using variable parameters.



Experiment example "Open-loop control of drive systems CLP 20"

Training contents

- Setting parameters, programming and utilising a programmable logic control unit
- Project planning and operation of an operator panel
- Setting parameters and operation of a frequency converter
- Project planning and operation of a field bus system
- Parameter optimisation on various adjustable working machines

From Simple Circuits to Process Control Using PROFI-safe

In Accordance with European Machine Guidelines

The training systems dealing with the topic of "Safety Technology" cover the subject's entire spectrum from simple circuits using safety relays to AS-i Safety with a safety monitor through to fail-safe process controls with PROFI-safe. Optical systems such as light curtains or laser scanners can also be easily integrated into these systems. The heart of the model is the protective door with safety position switch on which a wide range of safety applications can be trained.

The systems on safety technology are an excellent complement to the "Industrial Mechatronics System" IMS®.

The following systems are available:

- Circuits with safety control equipment
- AS-i Safety
- PROFI-safe
- Optical systems



Armed against danger

The advances made in automation processes also mean more potential for hazards affecting numerous workstations. Yet it is not just individuals who are exposed to danger through faulty operation or application; the machinery itself is also extremely sensitive. If certain safeguards are not undertaken, there is a risk of incurring considerable damage and losses. For that reason, employees must acquire precise knowledge of potential application faults.



Standardised precautions

In almost all manufacturing facilities and production plants a greater degree of flexibility is required despite continuously rising productivity and its associated accelerated material flows. It is thus essential that trainees are already able to employ and master the equipment to guarantee safety in automation engineering. The required safety precautions have been defined in the standard IEC EN DIN 61508.



Project work leads to increased safety

It is easier for students and trainees to comply with these standards and internalise the proper approach to safety technology when training is hands-on and practice-oriented. The training equipment combines practical application with theoretical material. A special manual – a feature of all Lucas-Nülle training systems – assists students in performing the practical exercises.



Circuitry Involving Safety Relays

Fundamentals: Safe and Secure with Contactors

The central model is a protective door with a safety position switch. Here various safety applications can be learned using the corresponding safety circuits:

- Safety position switch roller lever
- Safety position switch with separate actuator
- Safety position switch with tumbler
- Emergency shut-off

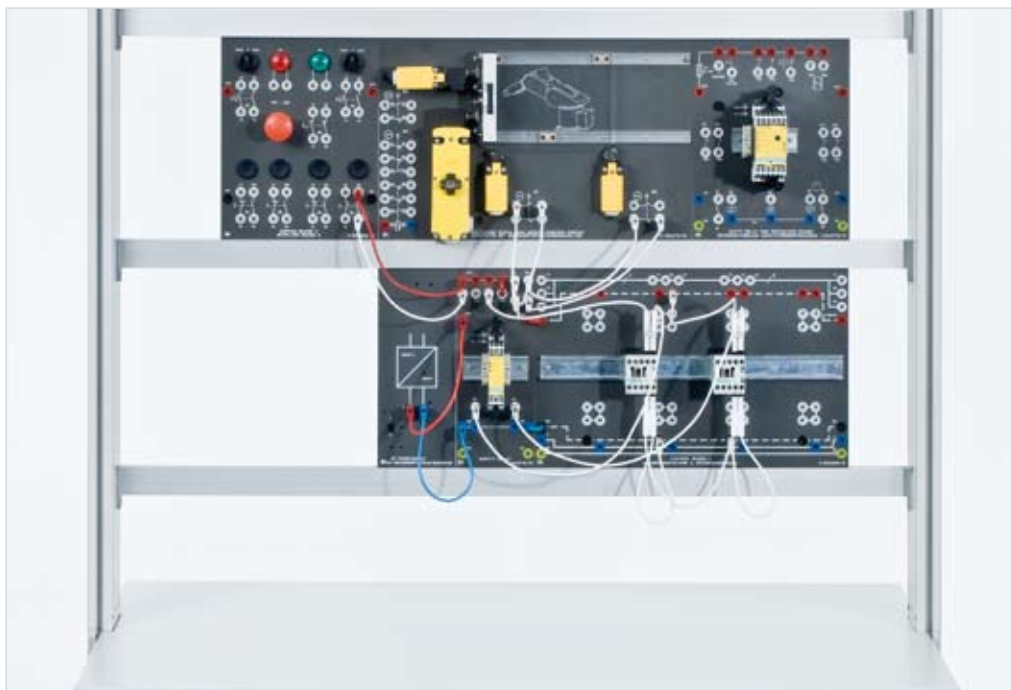

Experiment example "Circuits involving safety relays CSY 1"

Training contents

- Safety categories according to EN 954-1
- Redundant design of safety circuits
- Signalling a system's operating states
- Setting parameters and operation of safety control equipment
- Emergency shut-off
- Direct shut-off via a tumbler on the protective door

AS-i Safety

Conveying All Aspects of Safety Technology

The new safety system with AS-i Safety components is an excellent complement to the AS-i equipment set and covers all aspects of safety technology. The AS-i Safety monitor serves to keep track of all secure AS-i slaves on an AS-Interface network. Configuration of the AS-i Safety monitor is quick and easy with the software contained in this package. As such, connecting up components like an emergency shut-off button, protective door switch or the safety light grid to the AS-i network is very easy.

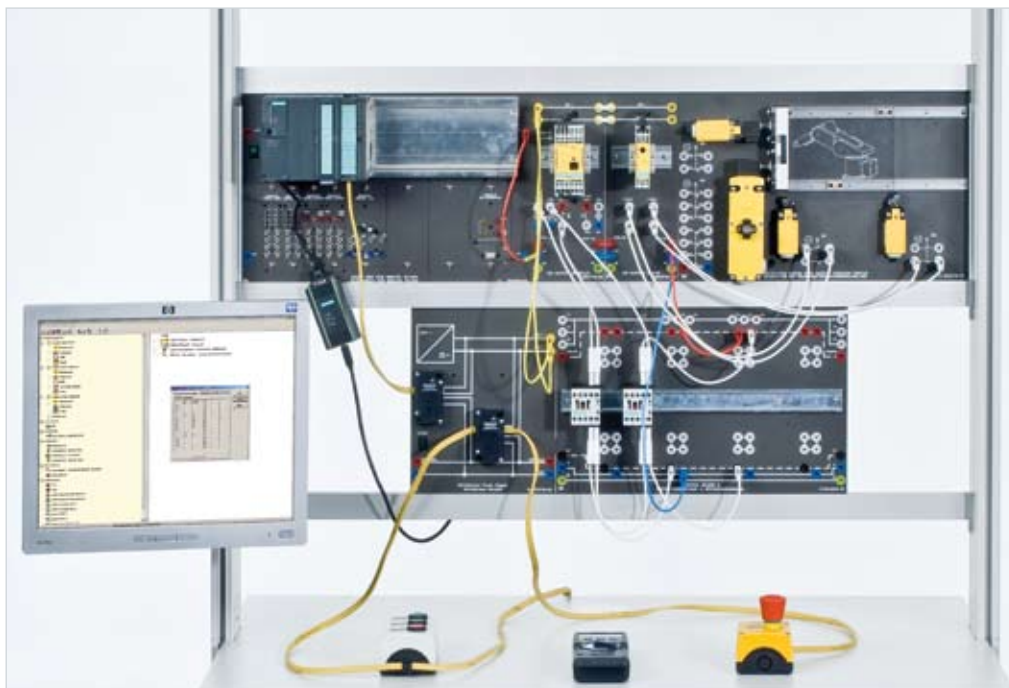

Experiment example "AS-i Safety at work CSY 2"

Training contents

- Safe AS-i sensors
- Putting safety application measures on an AS-Interface into operation
- Configuration of the AS-i Safety monitor
- Putting field bus systems into operation
- Combining normal and safe AS-i slaves

PROFIsafe

Networked Safety

Fail-safe signalling components monitor output and input signals. A CPU checks whether the control loop is operating properly by regularly initiating self-tests, instruction tests as well as logic- and time-dependent program operating checks. Furthermore, peripherals are also checked by polling them with a periodic watchdog signal.



Experiment example "PROFIsafe with 'safe' PLC CSY 3"

Training contents

- Operation of safety application measures on a PROFIBUS system (PROFIsafe)
- Programming with S7 Distributed Safety
- Deploying fail-safe function and data module

Optical Systems

All Systems Seen to Be Safe

Light curtains and light grids are used for non-contact safeguarding of hazardous areas. A light curtain or light grid consists of an emitter and a receiver. Infra-red LEDs on the emitter transmit a brief light pulse, which is captured by receiver diodes. The equipment set can be combined at will with all the other safety technology equipment sets.

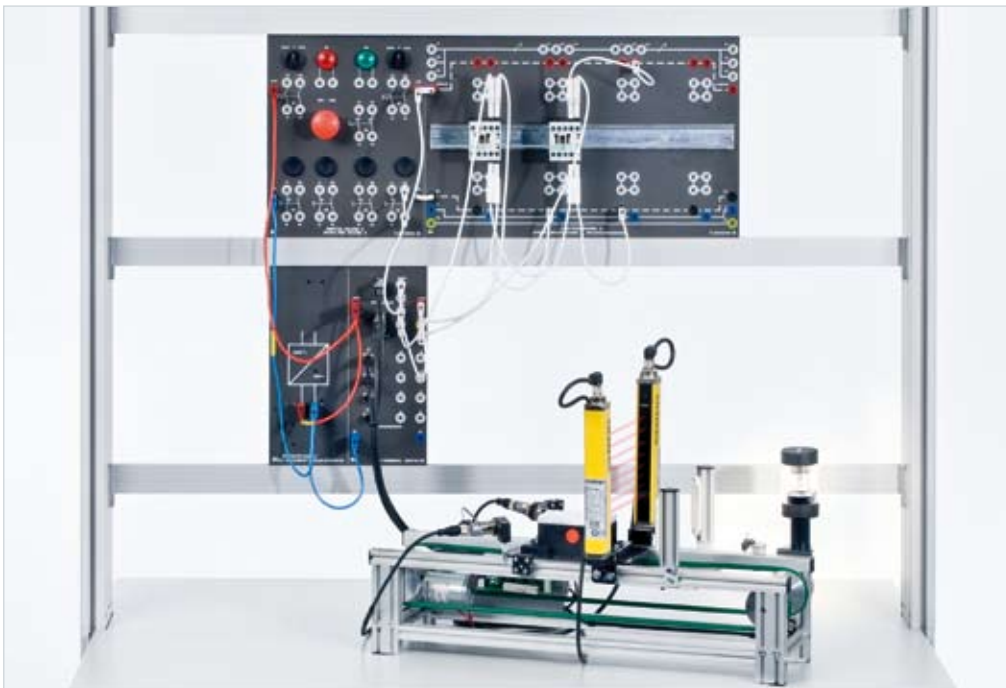

Experiment example "Optical safety systems CSY 4/5"

Training contents

- Setting up a light curtain
- AS-i Safety
- PROIsafe
- Muting (CSY 5)

System Models and Process Simulation

Ensuring Quality Early On – in the Planning Stage

Process simulation makes it possible to develop an optimum conceptual solution, which provides a competitive edge in terms of cost-efficiency, time and quality. This is how the planning stage is utilised to boost productivity and process reliability, put forward new visions and convert them into viable concepts.

Example benefits of process simulation:

- Quality improvement
- Reduction in throughput times
- Optimisation of resource utilisation
- Acceleration of response potential
- Enhancement of flexibility
- Cost cutting
- Profit maximisation



Virtual production

Virtual imagery can practically reproduce real industrial applications. This makes it possible to simulate and analyse working procedures and processes without interrupting actual running production lines. The objective is to identify and exploit hidden potential in the production process.



Configurable production systems

The variety of different process models and simulations permits hands-on experiments and learning to be targeted towards practice-oriented training. Unlimited possibilities can be opened up by creating your own production processes.



Training systems

The following training systems are the foundation for conveying the basics as well as advanced knowledge of PLC programming:

- The UniTrain-I multimedia range "Automation engineering" is the ideal choice for starting initial programming exercises
- The PCB models offer cost-effective PLC system models for digital signal processing
- The system simulator provides you with the possibility of implementing any of 24 different processes in your syllabus
- The process model ProTrain features graphic depiction of complex processes
- The electrical system models are highly authentic hands-on system models



Multimedia-Supported Models

The Ideal Introduction

UniTrain-I multimedia courses on automation technology convey the knowledge and skills needed for understanding process control, as well as the operation and maintenance of modern process automation systems. Thanks to animations and numerous projects involving real systems, the fundamentals, principles and component features of automated processes and production plants (PLC, bus systems, pneumatic drives, sensors) are explored in a variety of courses.



UniTrain
SYSTEM

UniTrain-I course "PLC and bus technology"

Training contents

- Logical operations, memory functions, timer and counter functions, edge detection, control of programming processes, analog processing
- Project planning for an automation system
- Programming with STL and ST editors in accordance with IEC 1131-1
- Programmable using STEP 7 in FBD, LD and IL

Projects

- Traffic light control
- Cleaning system
- Signal lamps
- Ventilator control
- Light control

PCB Models

A Multitude of Models

LN has developed various printed circuit board models for students to explore and develop programming techniques involving constants, variables or block structures and for using PLC resources such as flags, timers and system functions. Thanks to clearly understandable process systems, learning success is rapidly achievable.



Experiment example "PLC printed circuit board – traffic light model CLC 33"

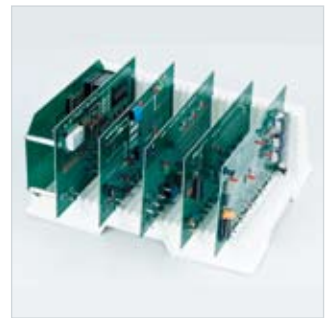

Total of six additional models with storage provision

Training contents

- Analysis of digital system processes
- Programming in accordance with IEC 1131-1 (STL, LD, SFC)
- Operating hardware models, testing and fault finding

Projects

- Traffic lights
- Stepper motor
- Star-delta reversing circuit
- Set-point/actual value comparison
- Tunnel/ventilation
- Washing machine
- Burglar alarm system

ProTrain Process Simulation

Making Complex Processes More Comprehensible

With this training system various automated processes can be realistically depicted and simulated at a workstation, without having to directly intervene in the production process. The I/O-interface uses a PC's serial interface to connect it to the digital and analog signal inputs and outputs of any programmable logic control system (PLC). The actuators in the model can be controlled directly by the PLC unit. The switching states of the signal generators are reported back to the PLC.



Experiment example "ProTrain process simulation (filling plant) CLC 35"

Training contents

- Control and testing of technical processes
- Setting parameters, programming and operation of various technical process systems
- Analysis of analog and digital system processes
- Programming in accordance with IEC 1131-1 (STL, LD, SFC)
- Fault finding in technical processes with malfunctions
- Simulation of system processes
- Centralised operation and monitoring of systems and processes

Pneumatics

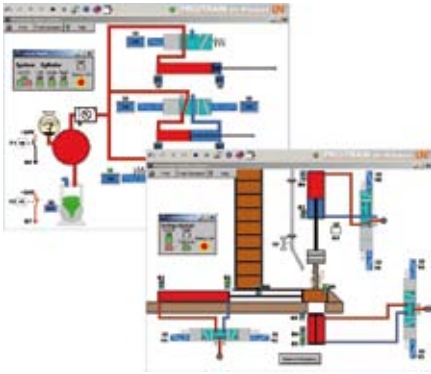

Basic circuitry and drilling device

Electrical machines

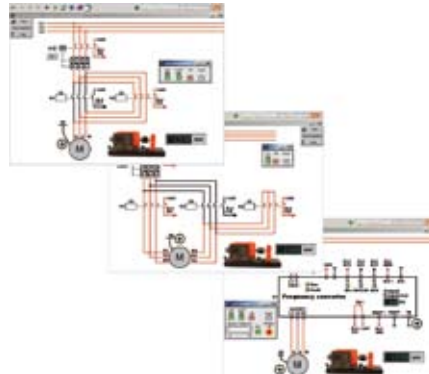

Reversing contactor circuit, star-delta starter circuit and frequency converter

Hydraulics

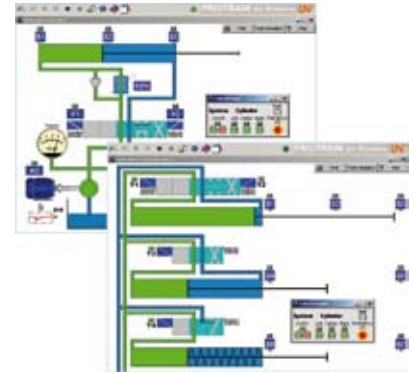

Hydraulic and servo drives

Manufacturing technology



Filling and sorting system

Process engineering

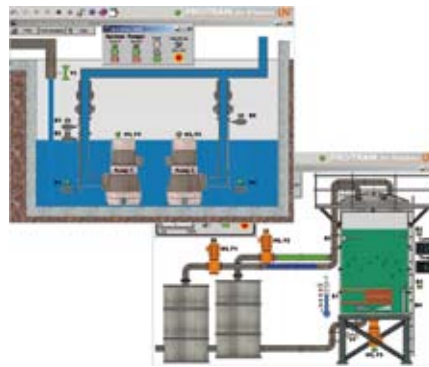

Pumping system and hybrid system

Developing your own process models

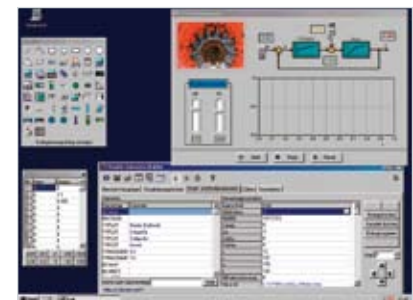

Benefits to you

- Simulation and visualisation of technological processes, machines and drives
- Design and operating response of processes are modelled in graphic realism and in full detail
- Process analysis with demonstration mode
- Disturbance scenarios are reproduced realistically in the process simulations
- Control errors are detected and logged
- Models are operated via integrated switches and pushbuttons
- For use in combination with real hardware for operation and monitoring (e.g. operator panel)
- Extensive online help via browser
- Developing your own process models

PLC Universal Process System Simulator

Set Up, Switch On and Practice

The PLC universal process system simulator has been designed especially for basic training in PLC technology. It is extremely well suited to graphic depiction and hands-on exploration of open-loop and closed-loop processes as found in industrial applications. By adding overlay masks, up to 24 different technical processes and models can be simulated. The projects are designed to precisely reflect official syllabuses.



Experiment example "PLC universal process system simulator CLC 34"



24 overlay masks

Projects

- Roadworks traffic lights
- Star-delta starting
- Dahlander circuit
- Starter control
- Monitoring facility
- Container filling system
- Sluice gate control
- Transfer platform
- Buffer storage
- Filling controlled system
- Mixing plant
- Compressed air network
- Cleaning tank
- Oven door control
- Bending tool
- Automatic stamping press
- Drilling device
- Selective band dividing filter
- Pipe bending system
- Door control
- Pump control 1
- Pump control 2
- Reaction vessel
- Pill filling machine

Electrical PLC Process System Models

Direct Connection to the Control System

With these compact training systems, subjects such as handling as well as transport and positioning processes can be explored. These constitute real life industrial conditions. Consequently they are ideally suited for learning process-oriented control programs and complex movement sequences and production processes.



Training contents

- Setting parameters, programming and operation of process controls
- Set-up and operation of hardware models, testing and fault finding
- Analysis of process sequences
- Programming in accordance with IEC 1131-1 (IL, LD, FBD)
- Programming sequence control
- Programming limit switches
- Manual, single-step and automatic operation

A Full-Scale Production Line "Industrial Mechatronics System" IMS®

From Individual Mechatronics Sub-Systems All the Way to Flexible FMS Production Lines

More complex training needs

Radical changes in the way people work have revolutionised the requirements and needs of how information and skills are taught and trained. As changes occur in company and factory processes, more and more importance is being assigned to such aspects as "operational competence" and "design of individual work processes" in day-to-day practice.

Integrating thought and action

Nowadays people being trained as automation engineers receive a broad "skills set" and qualifications in the most varied of technical disciplines. Performance objectives cover training in the assembly and mounting of system components and machinery, as well as in such practical applications as installation, operation and even maintenance of production lines, for which an understanding of the entire system is a prerequisite.

Changing educational approaches

These factors emphasise the need for a mechatronics training system to be the heart of a broad-based automation program to ensure to that theoretical technical knowledge is successfully cemented by means of realistically practical learning situations. The opportunity for students to learn using complex mechatronics training systems makes it easy for them to step up to industrial practice.



Modular design

IMS® is modularly designed so that functional systems of the most wide-ranging sizes can be designed. All of the sub-systems can be deployed individually or in any combination. For work-piece transport between individual sub-systems, a double conveyor belt system is used on which workpiece carriers travel.



Reflection or reality

With this training system, the industrial processes of a complex continuous production line are realistically simulated. The system exclusively employs industrial-type actuators and sensors. Furthermore, only industrial-type PLC systems with PROFIBUS and decentralised peripherals are used for process control.



Developing skills and expertise

The system promotes the training of skills and expertise during actual teamwork and enables the students and trainees to acquire the basics needed for the mastery of mechatronics systems in self-learning sessions. Each sub-system has been specially designed so that skills and knowledge are acquired gradually step-by-step right up to the point where a complete and sophisticated automatic production system has been created.



Sub-Systems at a Glance

Hands-On Training Guaranteed



1



Conveyor

5



Testing

9



Buffering

2



Sorting

6



Handling

10



Disassembly

3



Assembly

7



Storage

11



Robotics

4



Processing

8



Routing

11



Robotics

10



Education towards Industrial Standards

Simple Process Control

To control the individual work steps on a production line in order to put the entire system into operation is a process of some complexity. Therefore, achieving rapid set-up and installation is an important objective in training. By employing self-paced study using the UniTrain-I system and the Siemens SIMATIC S7-300 PLC, your students are optimally prepared for the task at hand. UniTrain-I offers a simple, didactically structured introduction to the control of each sub-system and is the preparation for integration and process control of production lines with industrial standard equipment using the Siemens SIMATIC S7-300 PLC.

- **UniTrain-I**
(Course work + experimenting + process control)

The individual sub-systems are controlled using UniTrain-I. This includes a fully integrated, fully fledged PLC with a PROFIBUS master. Your student will run his first PLC program within 10 minutes.

The multimedia courses convey the fundamentals of operation, design, definition and programming of process sequences for each of the sub-systems. Theory is reinforced with practical, hands-on experimenting.

- **Siemens SIMATIC S7-300**
(Process control with industrial standard equipment)

An entire production line comprising individual sub-systems can be controlled using, for example, the SIMATIC S7-300 from Siemens. This level of process control precisely reflects the realities found in industry.

Benefits to you

- **UniTrain-I**
 - Multimedia-based self-study course
 - Including control system with PROFIBUS
 - Fast progress due to extremely rapid set-up
 - Integrated development platform
- **Siemens SIMATIC S7-300**
 - Process control of the entire production line with industrial standard equipment
 - Communication via PROFIBUS, PROFINET, PROFI-safe and AS-i
 - Practical PLC
 - Use of STEP 7 as well as decentralised peripherals



Rapid Set-Up and Installation Guaranteed

UniTrain-I self-study system

- Small groups of students each set up and learn to operate a sub-system with the UniTrain-I control system
- Thanks to extremely fast set-up times, the students can be implementing their **first PLC program within 10 minutes**
- By the use of the accompanying multimedia-based self-study course, the instructor has **more time to provide individual instruction** to students and groups



Siemens SIMATIC S7-300 PLC control system

- A complete class of students can set up and operate a full-length IMS® production line with the S7 PLC control system
- Consequently the students are able to learn hands-on how of production **standard eq**



Easy Access to Each Sub-System

Hands-On Training Guaranteed

The UniTrain-I multimedia experiment and training system uses informative text, graphics and animations in a clearly structured course software to guide students through the experiments. In addition to the training software, each course comes with an experiment card including a control unit on which the practical exercises can be performed.



Benefits to you

- Educationally designed implementation and operation of all conveyor belts and sub-systems
- Integration of both cognitive and "hands-on" training material
- Strong linkage between theory and practice
- Rapid learning advances thanks to structured course design
- Extremely rapid set-up and assembly
- Courses structured into:
 - Training objectives/content
 - Hardware description
 - Software description
 - Basic knowledge
 - Experiments
 - Fault simulation and competency testing

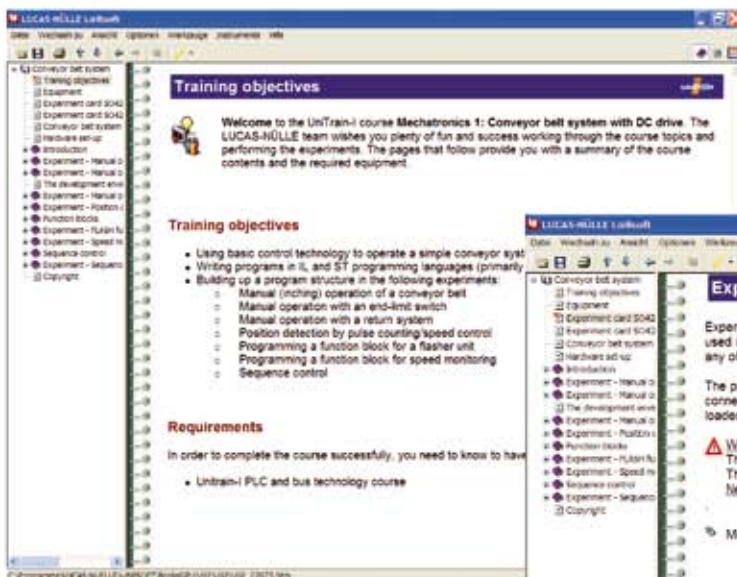

Systematic arrangement of training objectives

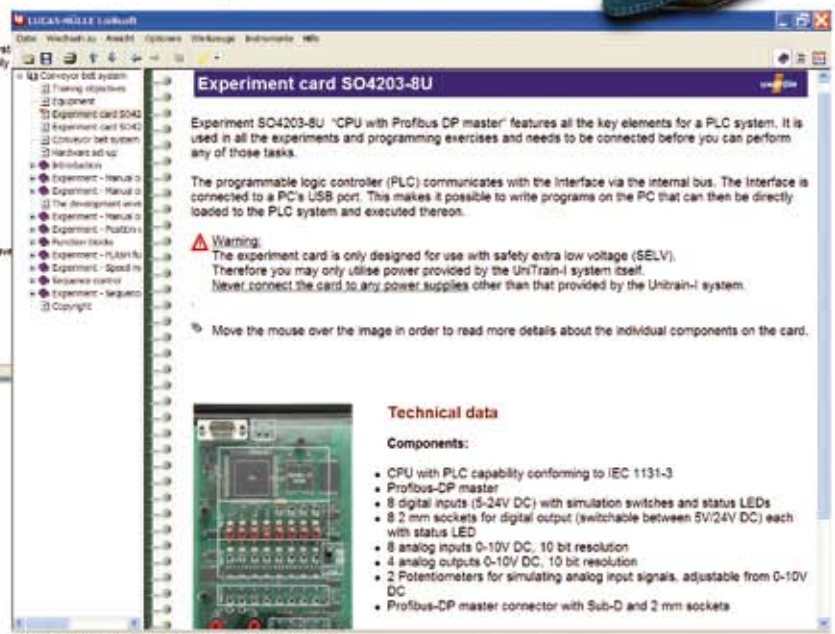

Experiment cards - contain all central elements of a PLC



Comprehensive coverage of theory

Logic diagrams

What is the most practical way of implementing a control system?

The key step in preparing a control system is to create a logic diagram (sometimes called a function block diagram). This logic diagram describes the precise functionality of the control system in graphical form. Details of logic diagrams are expanded upon in the following treatment.

A control system is used to automate technical equipment, be it a production line, a chemical plant, a car or even a domestic appliance. Automation engineers are not usually the experts responsible for the plant itself. That job is usually handled by plant engineers. Plant engineers are very often therefore the customers ordering a control system that will be implemented by an automation engineer.

To ensure that the control system controls the equipment "correctly", the relevant information for the control system needs to be communicated from the customer to the implementing engineer in a suitable form. The steps involved in this process are illustrated in the following diagram.

```

    graph TD
      A[Concept development of control system functions] --> B[Detailed development of control system functions in ladder logic]
      B --> C[Implementation of control system]
      C --> D[Test of functionality and commissioning]
    
```

Implementation

First of the following program and test it out:

```

    .....
    Build on the following I/O diagram:
    - 400V 50Hz 3x3 WGL
    .....

    TR AT #X0.3 : 00014 *Push button for moving left increasingly open
    TR AT #X0.4 : 00014 *Push button for moving right increasingly open
    QR AT #Q2.0 : 00014 *Output for right movement*
    QL AT #Q2.1 : 00014 *Output for left movement*

    END_VAR
    
```

When you have entered the program and pressed the "Run program" button, open the PLC virtual instrument by clicking on the image below. The PLC system should be in running mode. If it is not running then you have probably made an error your programming. Turn on the 24V DC power supply to the screwdriver belt by

Integrated development platform

Hardware set-up

The general hardware set-up illustrated below is used for all the experiments included in the course.

Set-up the hardware as shown in the animation below:

The UniTrain-1 Interface must be connected to both the standard power supply and the extended power supply.

Animated experiment set-ups

Logic diagram questions

Which of the following logic diagrams is/are valid for the manual operation experiment?

A logic diagram with two normally open contacts in series leading to a coil.

A logic diagram with two normally open contacts in parallel leading to a coil.

A logic diagram with one normally open contact and one normally closed contact in series leading to a coil.

A logic diagram with one normally open contact and one normally closed contact in parallel leading to a coil.

More than one answer may be correct.

Check answers

Interactive knowledge test

IMS® Conveyor Belt Systems and Sub-Systems

IMS® conveyor belt systems

The conveyor belt system is the element that connects all of the sub-systems and thus forms the backbone of the entire production line.



Benefits to you

- In the IMS® production line the conveyor belt systems are self-contained modules, which can be integrated with the sub-systems as needed
- Each conveyor belt module is supplied with its own UniTrain-I course
- Basic processes like "positioning" and "speed" can be demonstrated with just this simple system

IMS® sub-systems

Every step of a manufacturing process can be emulated by the "Industrial Mechatronics System" IMS® and its sub-systems.



Benefits to you

Lessons can be designed to suit your needs

- Practice on a specific sub-system or
- Practice on a set of individually selected sub-systems:
 - Subject matter can be adapted to varying degrees of trainees' existing knowledge
 - Particular sub-systems can be extended into custom assembled production lines
 - Each sub-system already possesses the control units, development environment and relevant multimedia training courses for self-paced study by students

IMS® 1.1 - Conveyor belt, unpowered

(For extensions to IMS® 1.2 and IMS® 1.3)

IMS® 1.2 - Conveyor belt, DC

(24 volt DC motor with variable speeds)

IMS® 1.3 - Conveyor belt, AC

(Three-phase frequency-controlled motor with frequency converter permits continuously variable speed)



Training contents

- Generating controlled movements along an axis
- Incremental positioning of a workpiece carrier
- Interlocking of forward motion and reverse motion
- Programming slip and standstill monitoring
- Working with different safety and interlocking circuits
- Understanding how sensors function and operate
- Connecting and using a PROFIBUS DP field bus system

IMS® 2 - Industrial sensors

Situation

Placed on the conveyor belt is a workpiece carrier with a machined workpiece.

- ▶ The conveyor belt transports the workpiece to the test station,
- ▶ Where various sensors and attachments are used to determine the workpiece's colour and material.
- ▶ Select the sensor most suited for the required application.
- ▶ The IMS sensor case is meant for experiments with industrial sensors in the IMS-System.



Training contents

- Assembly, setting and testing of various proximity switches
- Examining the sensors' operating principles using various experimental setups
- Assembly and functionality of the following sensors:
 - Inductive proximity switch
 - Capacitive proximity switch
 - Reflection light sensor
 - Reflection light barrier



IMS® Sub-Systems

IMS® 3 - Sorting

Example

A workpiece carrier is located on the conveyor belt

- ▶ The carrier is positioned under the shaft for the gravity-feed magazine
- ▶ The sorting station has a magazine that accommodates six top or bottom pieces
- ▶ The sorting station has a stack magazine for six workpiece substructures
- ▶ One piece is selected and placed in the carrier
- ▶ The carrier and its load are then conveyed to the end of the belt to be passed on to the next sub-system

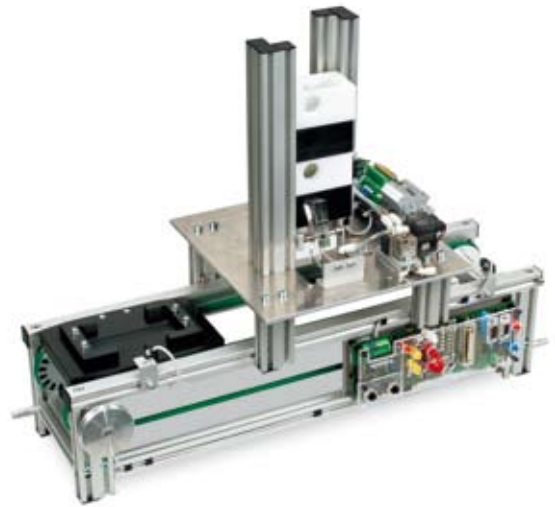

Training contents

- Assembly, set-up and testing of pneumatic cylinders and valves
- Introduction to subsystems for workpiece substructures
- Defining processes for sorting
- Programming of production sequences in manual and automatic modes

IMS® 4 - Assembly

Example

A workpiece carrier is located on the conveyor belt with a substructure

- ▶ The carrier is positioned under the shaft for the gravity-feed magazine
- ▶ The sorting station has a stack magazine for six workpiece superstructures
- ▶ One piece is selected and placed in the carrier mounted on the substructure
- ▶ The carrier and its load are then conveyed to the end of the belt to be passed on to the next sub-system

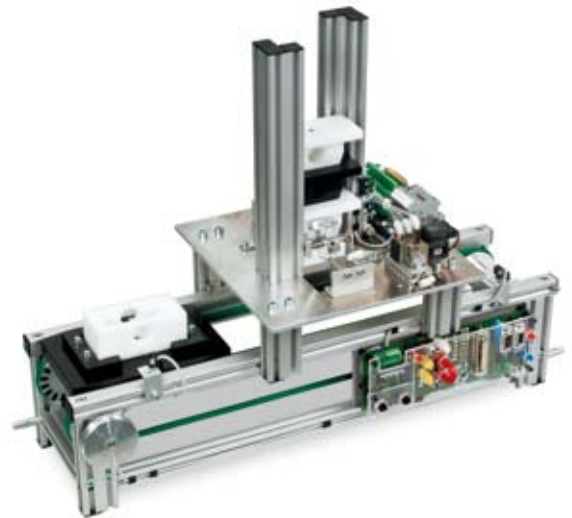

Training contents

- Assembly, set-up and testing of pneumatic cylinders and valves
- Introduction to subsystems for workpiece superstructures
- Defining processes for assembly
- Programming of production sequences in manual and automatic modes

IMS® 5 - Processing

Example

A workpiece carrier is located on the conveyor belt. It is loaded with a fully assembled two-component workpiece (top and bottom pieces)

- ▶ The carrier and its load are positioned beneath the process module
- ▶ The workpiece is clamped for processing
- ▶ A bolt from the gravity-feed magazine is pressed into the hole in the workpiece
- ▶ The clamp opens and the carrier and load are conveyed to the end of the belt to be passed on to the next sub-system

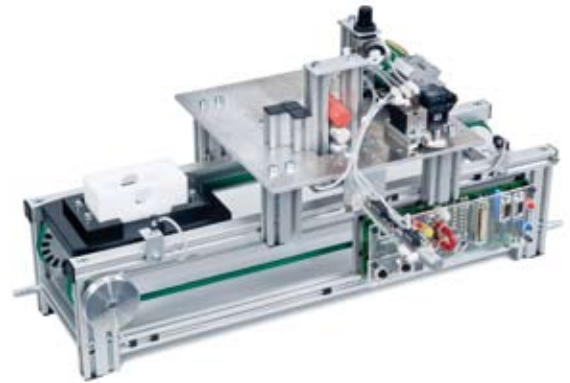

Training contents

- Assembly, set-up and testing of pneumatic cylinders and valves
- Identification of workpieces
- Monitoring of a process sequence
- Definition of a process sequence for simple processing
- Programming of production sequence in manual and automatic modes

IMS® 6 - Testing

Example

A carrier with a fully assembled workpiece is located on the conveyor belt

- ▶ A stopper positions the piece alongside the sensors
- ▶ The sensors detect the colour of the piece, its material and optionally its height
- ▶ Test data will be saved for subsequent processes
- ▶ After each successfully completed test the carrier is conveyed to the end of the belt to be passed on to the next sub-system

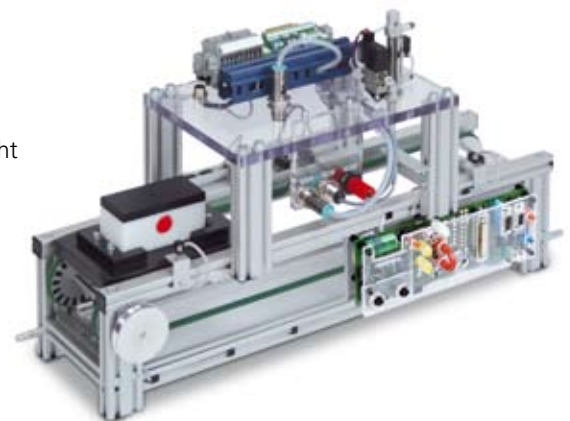

Training contents

- Assembly, set-up and testing of pneumatic cylinders and valves
- Optical, inductive, capacitive and magnetic test sensors
- Definition of process sequence for simple testing
- Programming of testing sequence in manual and automatic modes

IMS® Sub-Systems

IMS® 7 - Handling

Example

A carrier with a fully assembled and tested workpiece is located on the conveyor belt

- ▶ A handling station is located above the middle of the conveyor belt
- ▶ The carrier is stopped at the removal position
- ▶ The handling module lifts up the workpiece and transfers it to a different position
- ▶ The empty carrier is conveyed to the end of the belt to be passed on to the next sub-system

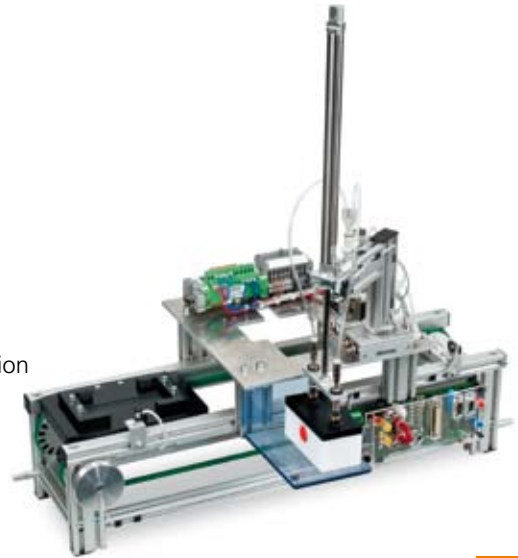

Training contents

- Assembly, set-up and testing of pneumatic cylinders and valves
- Vacuum generator, suction mechanism with sensors
- Definition of process sequence for simple workpiece sorting
- Set-up and control of a pneumatic linear unit
- Programming of sorting sequence in manual and automatic modes

IMS® 8 - Storage

Example

A carrier with a fully assembled and tested workpiece is located on the conveyor belt

- ▶ The carrier is stopped at the removal position
- ▶ The handling module lifts up the workpiece and transfers it to one of twenty possible storage positions
- ▶ The storage positions can be chosen according to the production task and test results
- ▶ The empty carrier is conveyed to the end of the belt to be passed on to the next sub-system



Training contents

- Assembly, set-up and testing of pneumatic cylinders and valves
- Definition of process sequence for automated storage and retrieval systems
- Detection of storage coordinate by means of incremental sensors
- Programming of a process chain
- Programming of complete warehousing process in manual and automatic modes

IMS® 9 - Routing

Example

A workpiece carrier is located on the conveyor belt

- ▶ The routing unit receives the carrier and transfers it to a revolving transport unit
- ▶ The revolving unit can determine the further routing of the carrier
- ▶ The carrier can be picked up and passed on in any one of three positions



Training contents

- Assembly, set-up and testing of pneumatic cylinders and valves
- Introduction to a conveyor routing unit
- Definition of process sequence
- Programming of production sequence in manual and automatic modes

IMS® 10 - Buffering

Example

The conveyor belt is equipped with two lifting units for buffering or queuing workpieces in complex mechatronics systems

- ▶ The buffer controls the flow of materials
- ▶ The carrier is lifted from the conveyor belt by a lifting unit and deposited in a magazine, while the belt continues moving with other pieces
- ▶ Up to four laden or 10 unladen workpiece carriers can be held in store
- ▶ The lifting unit can set the workpiece back onto the conveyor when necessary



Training contents

- Assembly, set-up and testing of pneumatic cylinders and valves
- Introduction to a buffering unit
- Definition of process sequence
- Programming of production sequence in manual and automatic modes

IMS® Robot Technology

IMS® 11 - Disassembly by robot

Example

A carrier with a fully assembled and tested workpiece is located on the conveyor belt

- ▶ The carrier is stopped at the removal position
- ▶ The robot lifts up the workpiece and transfers it to the dismantling station
- ▶ The workpiece is clamped in place
- ▶ The individual pieces of the workpiece are taken apart
- ▶ The robot sorts the individual components into pre-defined storage places



IMS® 11.1 with aluminium profile trolley and PC



IMS® 11.2 and IMS® 5 with aluminium profile trolley and PC

Training contents

- Assembly, set-up and testing of pneumatic cylinders and valves
- Introduction to the disassembly module
- Definition of process sequence
- Programming of production sequence in manual and automatic modes
- "Teaching" the robot in manual and automatic modes

Made to Meet Your Needs

Workforce training in automation requires a competence in robotics and its numerous applications in a production line.

For one group of students, rapid deployment in the minimum of space can be essential. For another, it may be more important to emulate industrial realities as closely as possible.



Direct human-robot interaction

Robot from IMS® 11.1



Automobile industry standard

Robot from IMS® 11.2

Benefits to you

• Neuronics Katana6M

- Compact personal robot with five degrees of freedom and six drives
- Direct interaction possible between human and robot
- No special safety equipment is required (as per EU risk analysis)
- Rapid programming and redeployment
- Simple programming by means of manual "teaching"
- Intuitive operation
- Minimal footprint

• Kawasaki FS 003N

- Compact, high-speed handling robot as used in industry, with six degrees of freedom
- Professional training system to provide "real life" experience
- International standard for automobile work. Common industrial design
- Programming using Kawasaki's AS language or function block programming languages via "Teach Pendant"
- Programming and operation via laptop with supplied software
- PLC functionality

From IMS® Sub-Systems to IMS® Production Lines

Advanced Teaching Structure

By assembling a variety of sub-systems, the "Industrial Mechatronics System" IMS® can integrate individual process steps to form a complete production line. This allows a realistic demonstration of interdependent production processes.

IMS® 23 - Production line with 3 sub-systems

IMS® 3 - Sorting, IMS® 6 - Testing, IMS® 7 - Handling

IMS® 3 - Sorting

An empty carrier is conveyed into the station and positioned under a gravity-feed magazine where a bottom section for a workpiece is selected and loaded onto the carrier.

IMS® 6 - Testing

A carrier with a separate bottom component is conveyed into the testing station. Sensors are used to detect the material of the workpiece and store the information for subsequent processes.

IMS® 7 - Handling

After testing, the workpiece is transported to a removal station. The component is then placed in one of two locations according to the results of the testing.

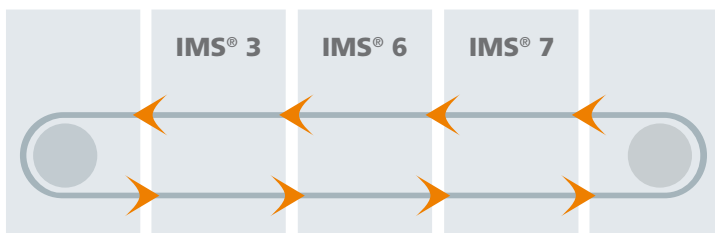

Benefits to you

- Mix and match sub-systems to assemble custom production lines based on your design, available budget, and space
- One production line can be skilfully used to teach fundamentals and advanced applications
- Modular design allows future expansion
- Add conveyor belt system to create a continuous, self-repeating production process

IMS® 24 - Production line with 4 sub-systems

IMS® 3 - Sorting, IMS® 4 - Assembly, IMS® 6 - Testing, IMS® 7 - Handling

As per IMS® 23, plus:

IMS® 4 - Assembly

A carrier loaded with a bottom piece arrives at the station and is positioned under the magazine. A top component is selected from the magazine and assembled on top of the bottom section.

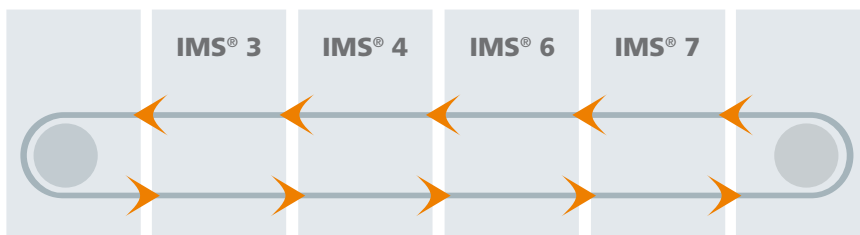

IMS® 25 - Production line with 5 sub-systems

IMS® 3 - Sorting, IMS® 4 - Assembly, IMS® 5 - Processing, IMS® 6 - Testing, IMS® 8 - Storage

As per IMS® 24, with IMS® 7 omitted but including:

IMS® 5 - Processing

A fully assembled two-component workpiece loaded on a carrier is conveyed on a belt into the station. It is positioned in the processing module and clamped into place. A bolt is selected from the magazine and pressed into the hole in the workpiece.

IMS® 8 - Storage

The return system features a storage and retrieval system with twenty storage cells. Workpieces can be stored on the rack according to the production job and test results. Empty carriers are then returned to the start of the production line.

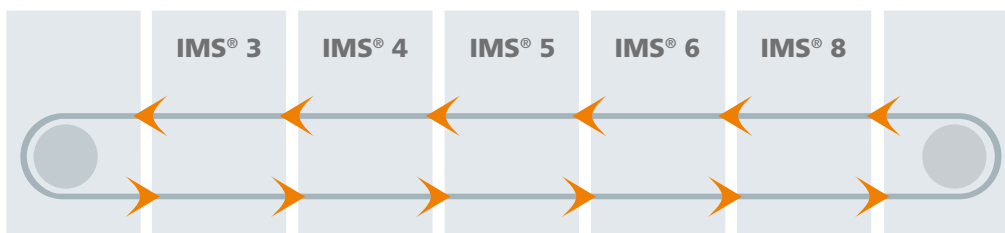

From IMS® Sub-Systems to IMS® Production Lines

IMS® 26 - Production line with 6 sub-systems

IMS® 3 - Sorting, IMS® 4 - Assembly, IMS® 5 - Processing, IMS® 6 - Testing, IMS® 8 - Storage, IMS® 11 - Disassembly

As per IMS® 25, plus:

IMS® 11 - Disassembly

A robot lifts the workpiece from the conveyor belt and places it in the disassembly station where it dismantles the piece into its individual components and sorts them into pre-defined storage locations.

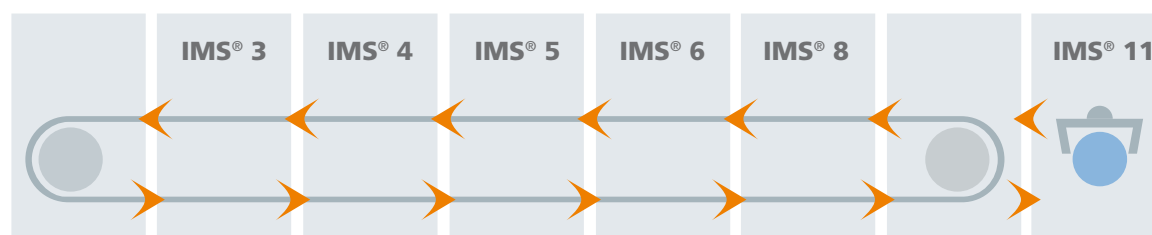

IMS® 28 - Production line with 8 sub-systems

IMS® 3 - Sorting, IMS® 4 - Assembly, IMS® 5 - Processing, IMS® 6 - Testing, IMS® 8 - Storage, IMS® 9 - Routing, IMS® 10 - Buffering, IMS® 11 - Disassembly

As per IMS® 26, plus:

IMS® 9 - Routing

The routing module can direct carriers to a different sub-system or otherwise change their direction of travel.

IMS® 10 - Buffering

If more than one carrier is on the belt, this sub-system can buffer the flow of materials by employing a lifting unit to raise the carrier off the belt entirely. It can then be replaced on the belt when necessary.

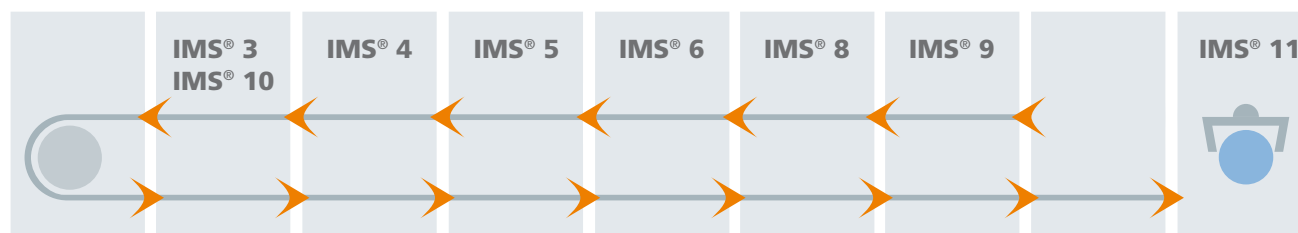

IMS® – Assembly Technology

Practical project assignments

The elements of the assembly-technology training case and transport-system kit can be combined in a variety of ways to construct machines, facilities and systems. System elements for protection and partitioning cover a wide spectrum of frames and racks designed to prevent persons from interfering in ongoing production processes and being consequently harmed by moving parts of an operational or production facility. Highly stable aluminium profiles can be used to quickly and neatly assemble any required structure without a need for additional surface finishing.



Case „Assembly technique“

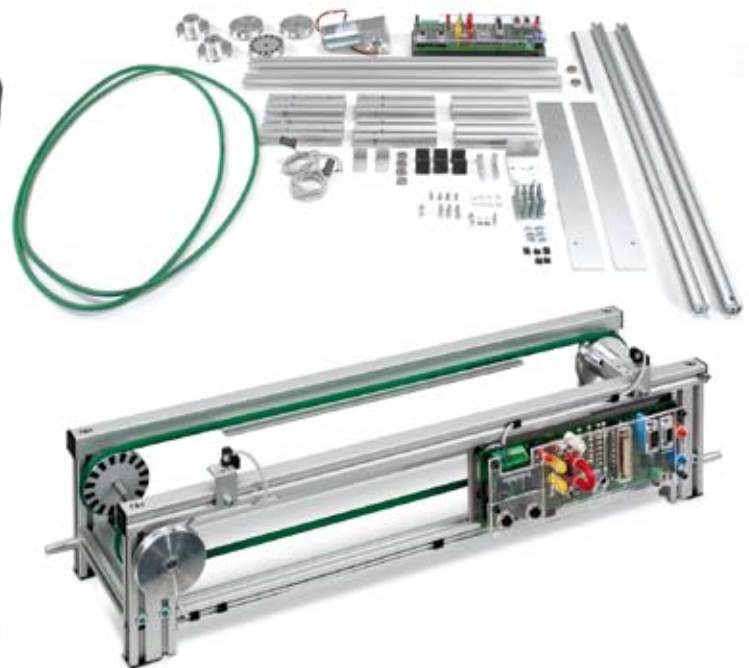

Construction set „Transport system kit“

Training contents

- Planning work steps followed by assembly
- Fundamentals of aluminium: Deposits, properties and manufacture
- Fundamentals of profiles: Extrusion, manufacturing process, bending
- Profile designs
- Connection technology
- Assembly tasks
- Technical drawings
- Part list processing

Additional learning objectives: Transport system kit

- Wiring technology
- Drive technology

IMS® – for Use with All Process Control Systems

Process Control Using Contactor Circuits or LOGO!®

Control of the IMS® system can also be performed by conventional industrial electronics techniques.

IMS® conveyors are ideally suited for small projects with contactor circuits.

LOGO!® Micro Automation Software by Siemens can be integrated seamlessly and expands the range of possible control mechanisms.

Our consultants will be delighted to provide you with additional information.

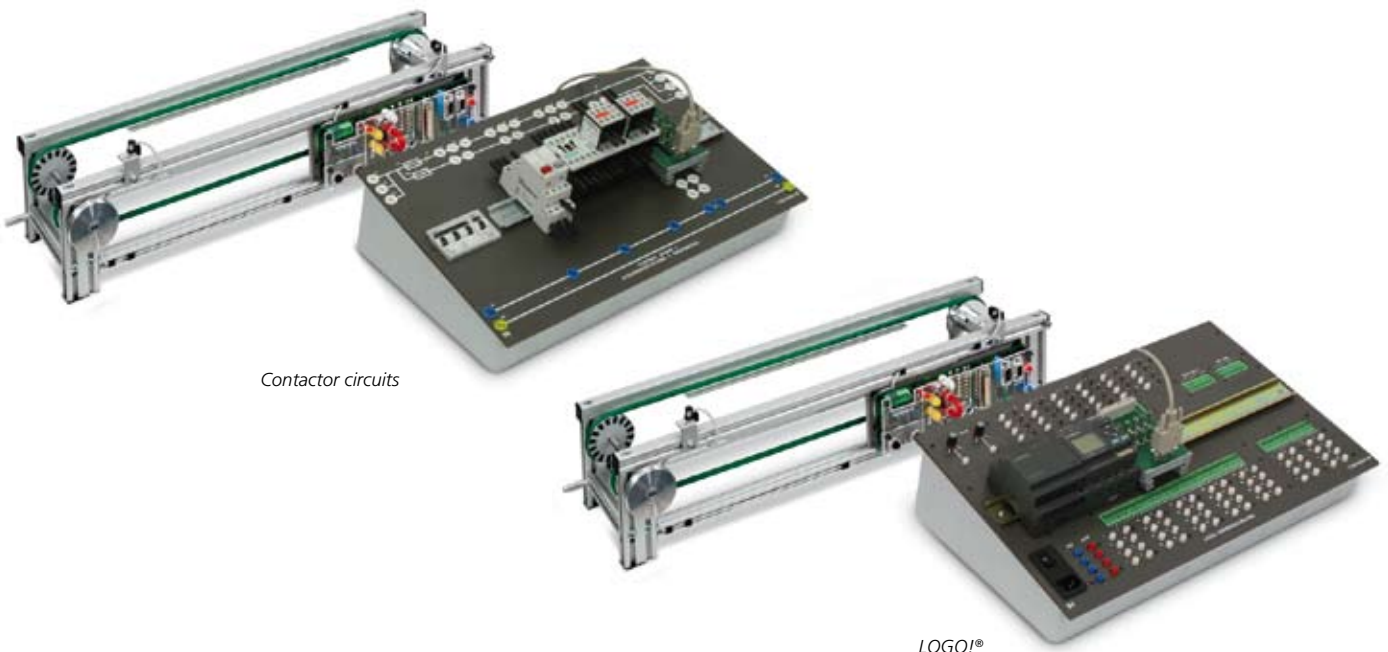

Benefits to you

- **Contactor circuits**
 - Conventional, connection-based process control programming
 - Introduction via simple exercises
 - Extensible for comprehensive process control projects
 - Preparation and implementation of process control projects using programmable logic control systems
- **LOGO!®**
 - First steps in programmable process control systems
 - Combination and expansion of existing process control tasks
 - Utilisation of LOGO!® Soft Comfort
 - Including multimedia self-study training course

IMS® Aluminium Profile Trolleys

Perfect Platform

To utilise the "Industrial Mechatronics System" IMS® to the best advantage, a range of trolleys built from aluminium profile frames is available that has been specially developed for use with the system.



Standard version
ST 7200-3U



Fully expanded version
ST 7200-3T

Benefits to you

- Trolleys custom-made to accommodate IMS® sub-systems
- Cascadable for production lines or pallet return systems
- Stability thanks to connecting mechanisms for combining elements into complete production lines
- Ease of working since panels simply slot into the experiment frames
- Standard trolleys can easily be expanded to make up a multi-functional experiment trolley
- A lower shelf can be installed to accommodate PCs, hydraulic units and compressors
- Optional extensions to hold keyboards and monitors

IMS® Virtual

The "Digital Factory": Realistic, Dynamic 3D Display

IMS® Virtual is a PC-based, graphical 3D simulation program, which provides a virtual learning environment for the IMS® mechatronics training system. The virtual sub-systems and production lines are depicted in real-time as a dynamically animated virtual 3D scene featuring all the components. The 3D scene can be programmed using STEP 7 just like a real production control system and is controlled by the "PLCSIM" software.

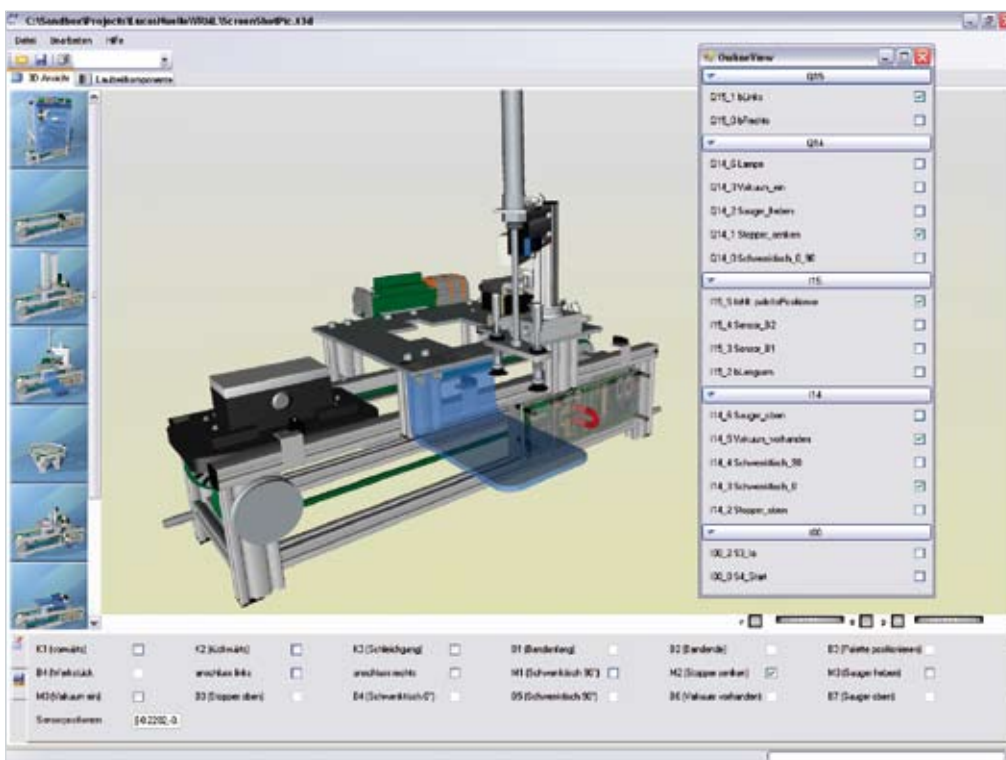

Teacher/student version of IMS® Virtual



Real hardware: IMS® 7 – Handling

Training contents

- Simulation and visualisation of technical processes
- PLC programming in accordance with IEC 1131-1 (IL, LD, FBD)
- Control and monitoring of technical processes
- Parameter setting, programming and commissioning of technically differing systems
- Systematic troubleshooting of production lines
- Central operation and monitoring of plant and processes
- Functions and system structure for a production line
- How an industrial robot operates within a production facility

Example Models of IMS® Sub-Systems and Production Lines

In the trainer/instructor version, with a few mouse clicks you can create almost any configuration of IMS® production line out of a library of virtual IMS® models.



IMS® 1 - Conveyor belt



*IMS® 3 - Sorting
and IMS® 4 - Assembly*

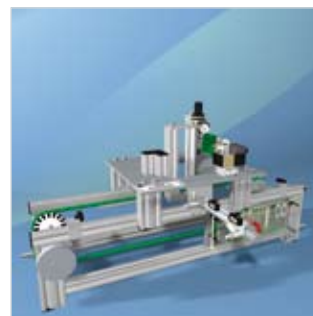

IMS® 5 - Processing



IMS® 6 - Testing



IMS® 7 - Handling



IMS® 8 - Storage

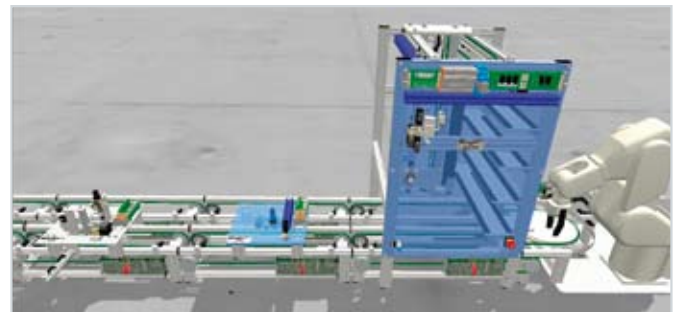

Production line IMS® 26 with industrial robot

Benefits to you

- Design and behaviour of processes are accurate in detail and clearly modelled in 3D
- A library is provided with working mechatronics sub-systems and production plants
- Real-time simulation
- Collision detection
- Fault simulation: configuration of errors in the adjustment of sensors or in electrical or physical properties of components
- Classroom licence including student and trainer/instructor versions
- Development of self-written process models with the expert version

Essential Product Benefits

Ensuring Long-Term Customer Satisfaction

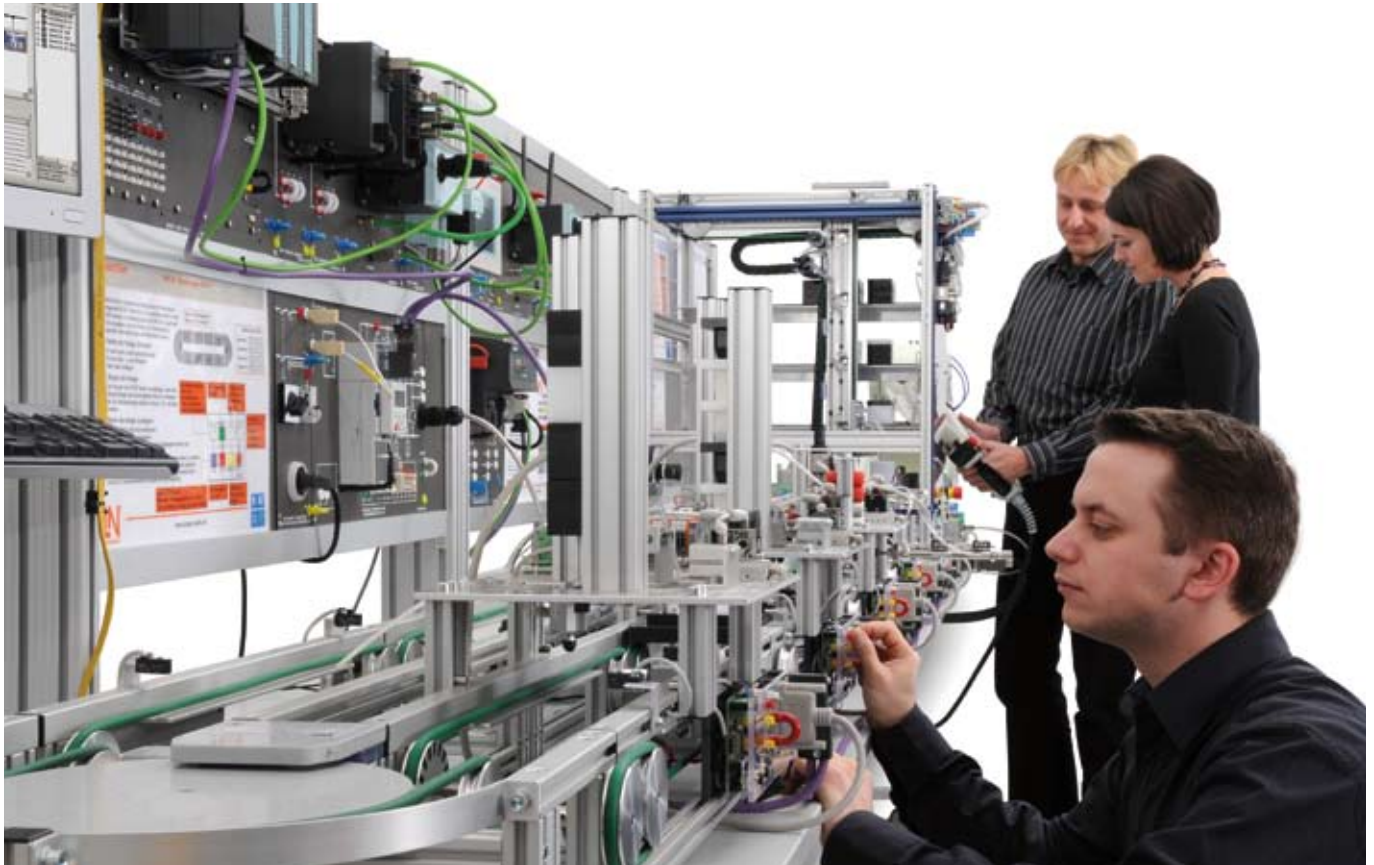

Michael Lorf, lecturer at the Leopold-Hoesch vocational college, Dortmund, Germany:

I'm a great fan of the "Industrial Mechatronics System" IMS. It's a flexible system that can always be put together in a different way depending on your needs. No other manufacturers offer anything like it. Its tremendous extensibility makes it quite simple to adapt it from parallel wiring to a bus system. The integration of frequency converters and RFID labels is also very useful from a training point of view.

We are using the "Industrial Mechatronics System" IMS in a pallet return system and have added safety equipment to it as well. That too was implemented without any difficulties.

The documentation is great as well.

IMS corresponds to genuine industrial standards. It is therefore ideal for use in project work involving authentic conditions. Components can easily be added, removed or relocated. It is ideal for **working in a classroom environment**. The robust design matches up to the tough demands of everyday life in schools and colleges.

Now we have a really great system that impresses not only teachers and students but also a great many of our visitors.

The Whole is Greater than the Sum of Its Parts.

Individual consultation with Lucas-Nülle

Do you require comprehensive advice or a firm offer?

Then you can contact us using any of the following means:

Tel.: +49 2273 567-0

Fax: +49 2273 567-39

Lucas-Nülle is a byword for custom occupational training courses in all of the following areas:



Electrical Wiring



Electropneumatics and Hydraulics



Electrical Power Supply Technology



Measurement and Instrumentation Technology



Power Electronics, Electrical Machines, Drive Technology



Microcomputers



Fundamentals of Electrical Engineering and Electronics



Automation



Communications Technology



Automotive Technology



Control Technology



Laboratory Systems

Ask us for detailed information using any of the given methods of contact

Our employees will be happy to advise you

Further information on our products can be found at the following web addresses:

www.lucas-nuelle.com

www.unitrain-i.com

Lucas-Nülle Lehr- und Meßgeräte GmbH

Siemensstraße 2 · D-50170 Kerpen-Sindorf
Telephone: +49 2273 567-0 · Fax: +49 2273 567-39
www.lucas-nuelle.com

